



TranTank[®]
INTERNATIONAL



TANKS LIQUID TRANSPORT



DIESEL REFUELING TANKS

2025 PRODUCT CATALOGUE



FIELD SPRAYER UNITS



FIRE FIGHTING EQUIPMENT

VALID FROM JANUARY 2025



TRAILED WATER CARTS



INDUSTRIAL WATER CARTS



WE DESIGN, DEVELOP AND MANUFACTURE LIQUID TRANSPORT TANK SOLUTIONS HERE IN AUSTRALIA

Built for the tough Australian landscape and exported across the world, we offer water cartage, weed spraying, diesel tank and fire fighting solutions for farmers and civil contractors.



25-YEAR TANK WARRANTY

Reliable, dependable solutions you could still be using 25 years from now



250+ ACTIVE STOCKING DEALERS

250+ Active Stocking Dealers Australia-Wide



LOCAL SERVICE & SUPPORT

Friendly, helpful Australian support team when you need it for the life of your product



100% AUSTRALIAN MADE & OWNED

Australian-owned and made for the tough Australian landscape



SAFEST TANKS IN MOTION

Reduce your risk with the true liquid transport tank specialists

DISCLAIMER
There may be information in our catalogue that contains typographical errors, inaccuracies, or omissions that may relate to product descriptions, specifications, pricing and other details. All weights, measurements and colours shown, are best approximations.

Trans Tank International (TTI) cannot guarantee and assumes no legal liability or responsibility for the accuracy or completeness of the information provided. The information contained in this catalogue is for general guidance only. TTI reserves the right to change, delete, or otherwise modify the information which is represented without any prior notice.



WHO WE ARE



WHO

**WE ARE HERE TO
SERVE HANDS-ON,
DOWN TO EARTH PRACTICAL
PEOPLE.**

Built in Australia, by Australians, for the tough Australian landscape



PURPOSE

**TO HELP DEVELOP
& PROTECT THE LAND.**

Helping you keep the weeds under control, your earthmoving equipment refueled, & fighting fire



CULTURE

**OUR CULTURE AND
CAPABILITY EQUAL
JUST RIGHT, FIRST
TIME, EVERY TIME.**

Our CRISP values underpin everything we do. Care, Respect, Innovation, Sincerity & Passion

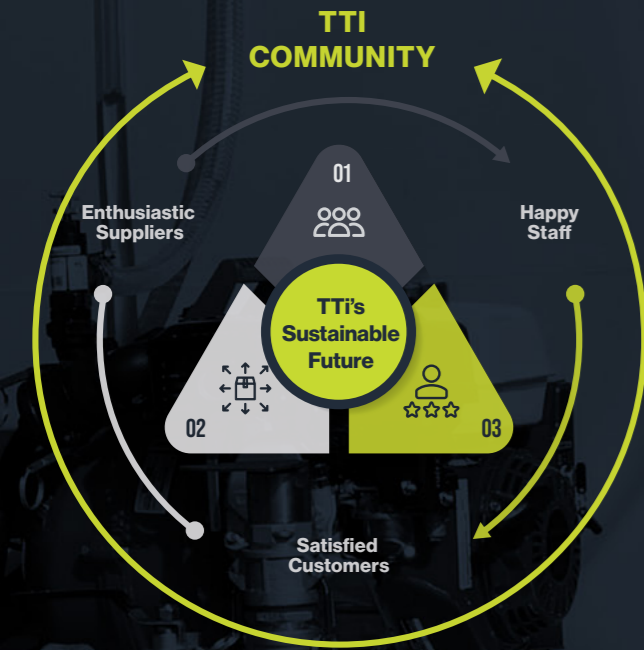

THE WORLD'S MOST RELIABLE LIQUID TRANSPORT TANK SOLUTIONS

TTi, or Trans Tank International is respected as Australia's Leading Manufacturer of rotationally moulded poly tanks, and has been for over 25 years.



NATHALIA
[HEAD OFFICE]



NATHALIA
[FABRICATION]



MELBOURNE
[WATER TRUCKS]

WHO ARE WE

WE PRIDE OURSELVES ON BEING:



ENVIRONMENTALLY AWARE

- ✓ We generate enough solar power to run our entire factory
- ✓ We commit to recycle wherever possible & continually economise our processes



COMMITTED TO THE HEALTH & SAFETY OF OUR PEOPLE

- ✓ We are passionate about OH&S and constantly strive for excellence
- ✓ We provide training & development for the personal enrichment of our staff

TTI VALUES



CARE



RESPECT



INNOVATION



SINCERITY



PASSION



MOULDING



FABRICATION



ADMINISTRATION



ASSEMBLY



WAREHOUSE

PRODUCT DIRECTORY

TANKS

LIQUID TRANSPORT TANKS



AquaTrans™ AquaMove™	14
AquaDelivery™	20
TransLoc™	22
InterLoc™	23
SumpTrans™	24
Tank Accessories	30

SPRAY

WEED SPRAYING EQUIPMENT



Inter™ Knapsack & Compression Sprayers	32
IK™ Industrial Sprayers	36
WeedMasta™ 16R	37
WeedControl™	38
WeedControl™	40
Strike™	42
ReelStrike™	43
OnDeck™	44

PRODUCT DIRECTORY

OnDeck™ (Standard)	46
OnDeck™ (Compact)	48
OnDeck™ with SuperReel™	50
SpotPro™	52
SpotPro™ (Deluxe)	53
TopCrop™	54
SuperReel™ (Single)	56
SuperReel™ (Twin)	58
TrailPro™	60
TrailPro™ (Deluxe)	61
TrailPro™	62
GlidePath™	64
SuperTrail™	66
SilageMaster™	68
LinkOn™	70
Spray Accessories	74
Remco	75
12v Pumps	75
Spray Hose	80
SuperReel™	81
Compact™	88
Pinnacle™ 'Plus'	89

DIESEL

DIESEL REFUELING TANKS



DieselSergeant™	94
DieselMajor™	95
DieselCaptain™	96
DieselCadet™	100
DieselCadet™ with Pump	104
Diesel Refueling Trailers	106
DieselPatrol14™	107
DieselPatrol15™	108
Diesel Accessories	112
BluEmission™	116

FIRE

FIRE FIGHTING EQUIPMENT



StandBy10™	118
BackUp16™	118
FireCombat™	120
FireGuard™	120

FireBoss™	121
FireDefence™	122
FireAttack™ Deluxe	124
FireAttack™	124
AquaPath™	126
FirePatrol14™	130
FirePatrol15™	132
PantherPatrol™	136

INDUSTRIAL

CIVIL WATER CARTS



PolymerPro™	138
Water Trucks	140
Water Trucks (4x2)	142
Water Trucks (6x4)	143
AquaModule™ (Chassis-Mount)	144
FloodRite™ (Slip-On Water Carts)	146
Hooklift™ (Hooklift Water Carts)	150
xTreme™ (Pressure Washdown Trailer)	152
xTreme™ (Plus)	153

WHAT'S NEW



See page 29

SumpTrans™ Tanks

Available in 8,000L, 10,000L & 12,000L

- ◆ Shallow Tank Feet
- ◆ Large, Deep Suction Sump
- ◆ Heavy Duty Pump Plate
- ◆ Agitator Mount Provisions



See page 51

OnDeck™ 100 - 150m SuperReel™

300L UTV Sprayer with Single/Twin Reel

- ◆ Single 100m or 150m 12v SuperReel™ Auto-rewind Reel
- ◆ Honda GX200 Engine
- ◆ Compact Design Suited for Kubota and LandBoss



See page 75

Remco 12v Pumps

Professional 12v Spray Pumps

- ◆ High Flow Rate with Less amp Draw
- ◆ Longer Duty Cycle
- ◆ 2000 Hour Life Expectancy
- ◆ 12-Month Warranty

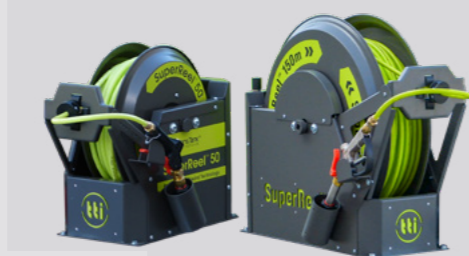

See page 81

SuperReel™ 50m & 100m/150m

Auto-Rewind 12v Reel - New Enhanced Design

- ◆ Powerful Belt-Driven 12v Motor
- ◆ Geared Reduction for Maximum Torque and Power Efficiency
- ◆ Easy Bolt-Down Points with Tough Powder-Coated Finish



See page 70

LinkOn™

3PL Sprayer

- ◆ Slotted Boom-Mount Brackets - for Easy Boom Height Adjustment
- ◆ New 'Compact' Boom Design - Reduced Stress on Boom and Sprayer
- ◆ Optional Side Step - for Easy Lid Access (600L - 1000L)



See page 136

PolymerPro™ 1000L & 2000L

Polymer Application Trailer

- ◆ Reliable Honda GX200 engine & 75L/min Bertolini Pump
- ◆ Heavy duty 36m x 19mm Hose reel with twist type nozzle
- ◆ 100L Tank Flush System



TANKS

LIQUID TRANSPORT

WHAT MAKES TTI'S TANKS UNIQUE?



Over 20 years specialising in the manufacture of quality water cartage tanks

TTi has over 20 years specialising in the manufacture of quality water cartage tanks. We do not dilute our focus by producing storage tanks and other rotomoulded products.





Did you know the DNA of every TTI tank is recorded? This combined with rigorous quality checks including ultrasound thickness testing and laboratory impact testing ensures that our clients are getting the very best available tanks on the Australian market, giving you peace of mind. Our unmatched tooling engineering is reflected in every moulded TTI Tank.

WATER CARTAGE TANKS

Tank Sizes:
20 to 17,000 Litres

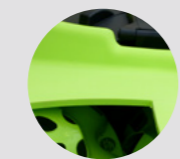

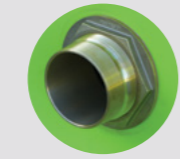
KEY FEATURES

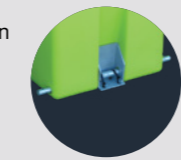
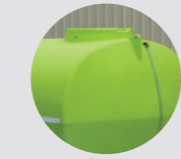
-  Extra thick tank wall structure with a load capacity of up to an enormous 1.3 Specific Gravity on all AquaTrans™
-  Easy-to-read calibration on side wall of tank for quick measurement of contents (when sight level tube is fitted)
-  Factory-fitted outlet with every tank
-  Exclusive, specially developed and formulated polyethylene powder incorporating the latest technology
-  Specifically designed footings to enable easy mounting to any tray surface - mounting pins included.
-  UV stabilised to withstand the elements; All tanks are cooked to temperature, not time

Suitable for



GET ANY TANK IN YOUR CORPORATE COLOUR

TRANSLUCENT

See the liquid level through the tank wall!



OPAQUE

Zero light penetration into tank



5% Colour Change Surcharge Applies

Note: Actual colours may vary slightly

SUPPLIED WITH PINS & WEDGES

FOR EFFECTIVE MOUNTING

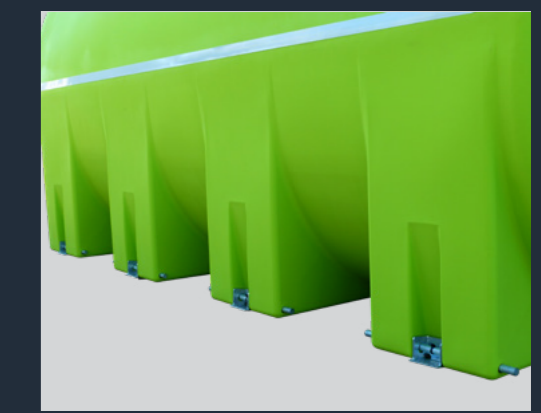

*Note: Wedges supplied for tanks 8,000L+

AQUATRANS™ / AQUAMOVE™

Water Cartage Tanks with 15 or 25-Year Warranty



SCAN TO SEE THIS PRODUCT IN ACTION!

WATER & FOAM TANKS

- UV stabilised for years of use
- Moulded inserts for mounting
- Tanks can be drilled and tapped to accept fittings

WATER



\$199* **10 Litres**

220mm(ø) x 460mm(H)
SKU: PTZV00010SG

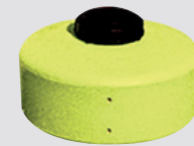

\$266* **35 Litres**

450mm(ø) x 400mm(H)
SKU: PTZV00025SG



\$392* **50 Litres**

450mm(ø) x 600mm(H)
SKU: PTZV00050SG



\$600* **100 Litres**

450mm(ø) x 950mm(H)
SKU: PTZV00100SG

FOAM

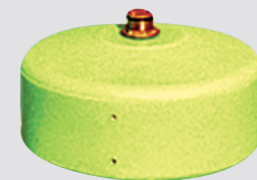

\$393* **35 Litres**

450mm(ø) x 400mm(H)
SKU: PTZB00025SG



\$525* **50 Litres**

450mm(ø) x 600mm(H)
SKU: PTZB00050SG



\$715* **100 Litres**

450mm(ø) x 950mm(H)
SKU: PTZB00100SG

450mm lid option available on some models

AQUATRANS™ / AQUAMOVE™

Water Cartage Tanks with 15 or 25-Year Warranty

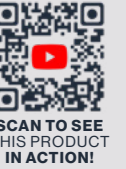

SCAN TO SEE THIS PRODUCT IN ACTION!



AquaTrans™ 25-Year Warranty

\$239* **20 Litres**

590 x 320 x 280mm (LWH)
ø100 Lid & Seal 3/4"
Poly Drain Bung & Seal
SKU: PTC00020SG



AquaTrans™ 25-Year Warranty

\$393* **50 Litres**

800 x 430 x 390mm (LWH)
ø150 Lid & Seal
3/4" Poly Drain Bung & Seal
SKU: PTC00050SG



AquaTrans™ 25-Year Warranty

\$590* **100 Litres**

900 x 450 x 475mm (LWH)
ø150 Lid & Seal
3/4" Poly Drain Bung & Seal
SKU: PTC00100SG



AquaTrans™ 25-Year Warranty

\$660* **200 Litres**

1000 x 650 x 600mm (LWH)
ø150 Lid & Seal
3/4" Poly Drain Bung & Seal
SKU: PTC00200SG



AquaTrans™ with 25-Year Warranty

\$675* **220 Litres**

925 x 710 x 510mm (LWH)
ø255 Lid Assembly
3/4" Poly Drain Bung & Seal
SKU: PTC00220SG

Steel Skid-Frame
SKU: ASF000220 **\$675***
Top-Mount Steel Pump Plate
SKU: SSF001 **\$295***



AquaTrans™ with 25-Year Warranty

\$1,200* **400 Litres**

1620 x 710 x 510mm (LWH)
ø255 Lid Assembly
3/4" Poly Drain Bung & Seal
SKU: PTC00400ASG

Steel Skid-Frame
SKU: ASF000400A **\$800***
Top-Mount Steel Pump Plate
SKU: SSF001 **\$295***

What's the Difference?

AquaTrans™ AquaMove™

AquaTrans™

There is nothing much in the way of a rotationally moulded polyethylene water cartage tank that compares with the TTI AquaTrans™ tank range.

A really heavy-duty tank with a 25-year warranty is just part of the deal. The AquaTrans™ is a premium product and is in a league of its own. This is the bees' knees!

AquaMove™

Without any compromise, the AquaMove™ range has been introduced to be a player in the price sensitive end of the market.

With a slightly lighter design than the AquaTrans™ and a 15-year warranty, this is the everyday range.

Water Cartage Tanks

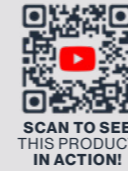

AQUATRANS™ / AQUAMOVE™

Water Cartage Tanks with 15 or 25-Year Warranty

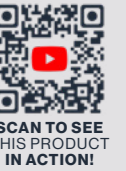

500 Litres

AquaTrans™ 25-Year Warranty
SKU: PTC00500SG

\$1,320*

1250 x 1070 x 580mm (LWH); Mounting Pins Provided; ø255 Lid, Rim, & Seal Assy; 1½" MBSP Fitting-Poly (fitted)



600 Litres

AquaTrans™ 25-Year Warranty
SKU: PTC00600SG

\$1,385*

1250 x 1070 x 740mm (LWH); Mounting Pins Provided; ø455 Lid, Rim, & Seal Assy; 1½" MBSP Fitting-Poly (fitted)

★ **LiquidLocker™ 16pcs** **\$208***



800 Litres

AquaTrans™ 25-Year Warranty
SKU: PTC00800SG

\$1,680*

1430 x 1220 x 670mm (LWH); Mounting Pins Provided; ø455 Lid, Rim, & Seal Assy; 1½" MBSP Fitting-Poly (fitted)

★ **LiquidLocker™ 17pcs** **\$221***



1,000 Litres

AquaTrans™ 25-Year Warranty SKU: PTC01000SG
AquaMove™ 15-Year Warranty SKU: STC01000SG

\$1,920*

\$1,780*

1430 x 1220 x 835mm (LWH); Mounting Pins Provided; ø455 Lid, Rim, & Seal Assy; 1½" MBSP Fitting-Poly (fitted)

★ **LiquidLocker™ 24pcs** **\$312***



1,200 Litres

AquaTrans™ 25-Year Warranty
SKU: PTC01200SG

\$2,120*

1720 x 1230 x 840mm (LWH); Mounting Pins Provided; ø455 Lid, Rim, & Seal Assy; 1½" MBSP Fitting-Poly (fitted)

★ **LiquidLocker™ 29pcs** **\$377***



1,500 Litres

AquaTrans™ 25-Year Warranty SKU: PTC01500SG
AquaMove™ 15-Year Warranty SKU: STC01500SG

\$2,470*

\$2,305*

1720 x 1230 x 1000mm (LWH); Mounting Pins Provided; ø455 Lid, Rim, & Seal Assy; 1½" MBSP Fitting-Poly (fitted)

★ **LiquidLocker™ 40pcs** **\$520***

AQUATRANS™ / AQUAMOVE™

Water Cartage Tanks with 15 or 25-Year Warranty

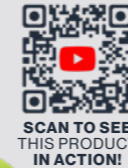

2,000 Litres

AquaTrans™ 25-Year Warranty
SKU: PTC02000SG

AquaMove™ 15-Year Warranty
SKU: STC02000SG

\$3,430* **\$3,235***

LWH: 2150 x 1410 x 870mm; Mounting Pins Provided; ø455 Lid, Rim, & Seal Assy; 2" MBSP Fitting-Poly (fitted)

- ★ LiquidLocker™ 55pcs **\$715***
- ★ Steel Mounting Frame **\$2,700***



2,400 Litres

AquaTrans™ 25-Year Warranty
SKU: PTC02400SG

\$3,905*

LWH: 2150 x 1410 x 1140mm; Mounting Pins Provided; ø455 Lid, Rim, & Seal Assy; 2" MBSP Fitting-Poly (fitted)

- ★ LiquidLocker™ 66pcs **\$858***
- ★ Steel Mounting Frame **\$2,700***



3,000 Litres

AquaTrans™ 25-Year Warranty
SKU: PTC03000SG

AquaMove™ 15-Year Warranty
SKU: STC03000SG

\$5,110* **\$4,445***

LWH: 2430 x 1540 x 1200mm; Mounting Pins Provided; ø455 Lid, Rim, & Seal Assy; 2" MBSP Fitting-Poly (fitted)

- ★ LiquidLocker™ 85pcs **\$1,105***
- ★ Steel Mounting Frame **\$4,205***



4,000 Litres

AquaTrans™ 25-Year Warranty
SKU: PTC04000SG

AquaMove™ 15-Year Warranty
SKU: STC04000SG

\$5,980* **\$5,660***

LWH: 2430 x 1540 x 1450mm; Mounting Pins Provided; ø455 Lid, Rim, & Seal Assy; 2" MBSP Fitting-Poly (fitted)

- ★ LiquidLocker™ 110pcs **\$1,430***
- ★ Steel Mounting Frame **\$4,205***



5,000 Litres

AquaTrans™ 25-Year Warranty
SKU: PTC05000SG

AquaMove™ 15-Year Warranty
SKU: STC05000SG

\$7,170* **\$6,430***

LWH: 2760 x 2000 x 1400mm; Mounting Pins Provided; ø455 Lid, Rim, & Seal Assy; 2" MBSP Fitting-Poly (fitted)

- ★ LiquidLocker™ 138pcs **\$1,794***
- ★ Steel Mounting Frame **\$5,525***



6,000 Litres

AquaTrans™ 25-Year Warranty
SKU: PTC06000SG

\$8,405*

LWH: 2760 x 2000 x 1540mm; Mounting Pins Provided; ø455 Lid, Rim, & Seal Assy; 2" MBSP Fitting-Poly (fitted)

- ★ LiquidLocker™ 165pcs **\$2,145***
- ★ Steel Mounting Frame **\$5,525***

AQUATRANS™ / AQUAMOVE™

Water Cartage Tanks with 15 or 25-Year Warranty

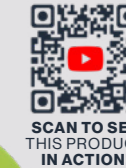

7,000 Litres

AquaTrans™ 25-Year Warranty
SKU: PTC07000SG

\$9,550*

LWH: 3390 x 2250 x 1390mm; Mounting Pins Provided; ø455 Lid, Rim, & Seal Assy; 3" MBSP Fitting-Brass

- ★ LiquidLocker™ 190pcs **\$2,470***
- ★ Steel Mounting Frame **\$6,940***



8,000 Litres

AquaTrans™ 25-Year Warranty
SKU: PTC08000SG

\$11,755*

LWH: 3600 x 2100 x 1540mm; Pins and Wedges Supplied; ø455 Lid, Rim, & Seal Assy; 3" MBSP Fitting-Brass

- ★ LiquidLocker™ 240pcs **\$3,120***
- ★ Steel Mounting Frame **\$6,940***



10,000 Litres

AquaTrans™ 25-Year Warranty
SKU: PTC10000SG

AquaMove™ 15-Year Warranty
SKU: STC10000SG

\$13,955* **\$12,120***

LWH: 3480 x 2250 x 1940mm; Pins and Wedges Supplied; ø455 Lid, Rim, & Seal Assy; 3" MBSP Fitting-Brass

- ★ LiquidLocker™ 295pcs **\$3,835***
- ★ Steel Mounting Frame **\$6,940***



10,000 Litres

AquaTrans™ 25-Year Warranty
SKU: PTC10000ASG

\$13,955*

LWH: 3600 x 2100 x 1880mm; Pins and Wedges Supplied; ø455 Lid, Rim, & Seal Assy; 3" MBSP Fitting-Brass

- ★ LiquidLocker™ 295pcs **\$3,835***
- ★ Steel Mounting Frame **\$6,940***



12,000 Litres

AquaTrans™ 25-Year Warranty
SKU: PTC12000SG

\$15,830*

LWH: 3600 x 2100 x 2240mm; Pins and Wedges Supplied; ø455 Lid, Rim, & Seal Assy; 3" MBSP Fitting-Brass

- ★ LiquidLocker™ 355pcs **\$4,615***
- ★ Steel Mounting Frame **\$6,940***



13,000 Litres

AquaTrans™ 25-Year Warranty
SKU: PTC13000SG

\$16,765*

LWH: 3480 x 2250 x 2310mm; Pins and Wedges Supplied; ø455 Lid, Rim, & Seal Assy; 3" MBSP Fitting-Brass

- ★ LiquidLocker™ 385pcs **\$5,005***
- ★ Steel Mounting Frame **\$6,940***

AQUATRANS™ / AQUAMOVE™

Water Cartage Tanks with 15 or 25-Year Warranty



SCAN TO SEE THIS PRODUCT IN ACTION!



13,000 Litres

AquaTrans™ 25-Year Warranty
SKU: PTC13000ASG

\$16,765*

LWH: 4310 x 2350 x 1795mm; Pins and Wedges Supplied;
2 x ø455 Lid, Rim, & Seal Assy; 3" MBSP Fitting-Brass

- ★ LiquidLocker™ 385pcs **\$5,005***
- ★ Steel Mounting Frame **\$7,785***

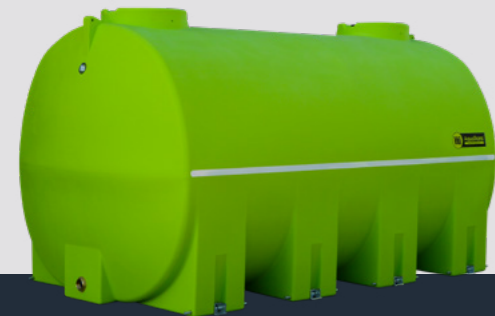

17,000 Litres

AquaTrans™ 25-Year Warranty
SKU: PTC17000SG

\$22,580*

LWH: 4310 x 2350 x 2395mm; Pins and Wedges Supplied;
2 x ø455 Lid, Rim, & Seal Assy; 3" MBSP Fitting-Brass

- ★ LiquidLocker™ 505pcs **\$6,565***
- ★ Steel Mounting Frame **\$7,785***



15,000 Litres

AquaTrans™ 25-Year Warranty
SKU: PTC15000SG

\$19,950*

LWH: 4310 x 2350 x 2040mm; Pins and Wedges Supplied;
2 x ø455 Lid, Rim, & Seal Assy; 3" MBSP Fitting-Brass

- ★ LiquidLocker™ 445pcs **\$5,785***
- ★ Steel Mounting Frame **\$7,785***



LOW-PROFILE DESIGN

FOR MAXIMUM VEHICLE STABILITY



The Locker that Stops The Slosh!

- ✓ **Complies with load restraint** guide performance standards
- ✓ **Suitable for use with all tanks** - poly, steel, fibreglass, aluminium, etc.
- ✓ **LiquidLocker™ baffles** can be used with water, diesel and other liquids
- ✓ **Simple to install** LiquidLocker™ baffles are supplied in two halves



LiquidLocker™
Anti-Surge Baffling Safety System
(Supply Only)

\$8*

Ø195mm

1 Ball per 5.8 Litres (1:6)

SKU: LLB195

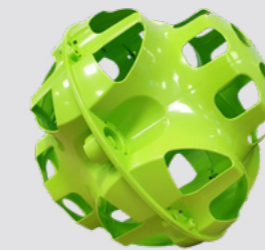

LiquidLocker™
Anti-Surge Baffling Safety System
(Supply Only)

\$11*

Ø380mm

1 Ball per 33 Litres (1:33)

SKU: LLB380

LiquidLocker Testing & Demonstration Results:

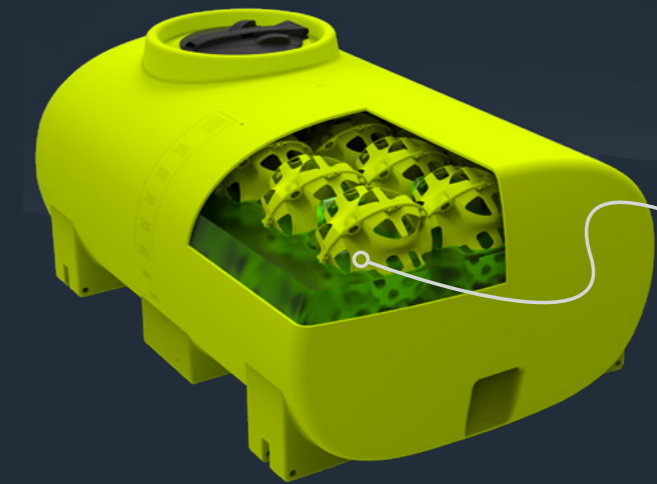

IT TAKES UP JUST
1.7%
OF YOUR TANKS
TOTAL VOLUME!

100%
ELIMINATION OF
LIQUID SURGE

80%
IMPROVED CORNERING &
MANEUVERABILITY

40%
SHORTER BRAKING
DISTANCE

50%
VEHICLE WEAR AND
TEAR REDUCTION

*Results may vary depending on tank size, vehicle & road conditions

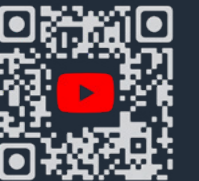

SCAN TO SEE
VIDEO
DEMONSTRATION!

AquaDelivery™

Bulk Water Delivery with Honda GX200 and 3" Water Delivery Pump

- ✓ Heavy-duty water cartage tank on forkable steel frame
- ✓ Honda GX200 (Electric Start) Motor with QP303 1000L/min Transfer Pump
- ✓ Lockable Toolbox with 2 x 10m Lengths of Certified Potable Food Grade Layflat Hose
- ✓ Hydrant Filler Lid with Spring non-return valve

Bulk Water Delivery Unit



CODE	CAPACITY (LITRES)	RRP*(\$)	CODE	CAPACITY (LITRES)	RRP*(\$)
PWD05000L	5,000 Litres	\$20,325*	PWD12000L	12,000 Litres	\$29,585*
PWD06000L	6,000 Litres	\$21,470*	PWD13000L	13,000 Litres	\$32,015*
PWD07000L	7,000 Litres	\$24,470*	PWD13000AL	13,000 Litres	\$32,015*
PWD08000AL	8,000 Litres	\$25,640*	PWD15000L	15,000 Litres	\$34,670*
PWD10000ALSG	10,000 Litres	\$27,760*	PWD17000L	17,000 Litres	\$37,010*

FRAMES

Forkliftable Tank Skids

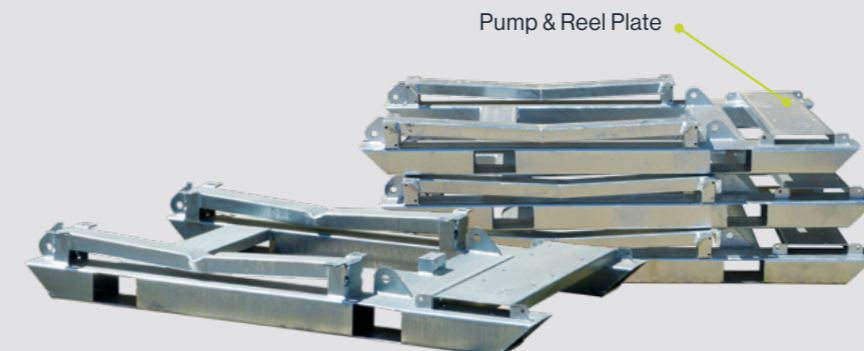

To Suit Tanks from 500L to 1,500L

Simple tank to frame SureFit mounting system
 TTI's steel frames are over engineered and hot dip galvanized for long lasting protection
 Frames standard with forklift pockets from all four sides

SKU	DESCRIPTION	KG	L X W (MM)	RRP* (\$)
ASFC00500	Steel Frame for 500L & 600L SumpTrans, includes forklift tine pockets on all sides	37	1630 x 1010	\$2,610
ASFC00800	Steel Frame for 800L & 1000L SumpTrans, includes forklift tine pockets on all sides	53	1780 x 1110	\$2,820
ASFC01200	Steel Frame for 1200L & 1500L SumpTrans, includes forklift tine pockets on all sides	72	1780 x 1344	\$2,990

*Disclaimer: Check compatibility with your forklift width between tynes



To Suit Tanks from 2,000L to 17,000L

Forkliftable for easy lift on, lift off convenience
 Simple tank to frame SureFit mounting system
 TTI's steel frames are over engineered and hot dip galvanized for long lasting protection

SKU	DESCRIPTION	KG	L X W (MM)	RRP* (\$)
ASFC02000	Steel Frame for 2000L & 2400L AquaTrans™	190	2910 x 1410	\$2,700
ASFC03000	Steel Frame for 3000L & 4000L AquaTrans™	218	3020 x 1355	\$4,205
ASFC05000	Steel Frame for 5000L & 6000L AquaTrans™	302	3500 x 1820	\$5,525
ASFC07000	Steel Frame for 7000L, 10000L & 13000L AquaTrans™	410	4100 x 2200	\$6,940
ASFC08000	Steel Frame for 8000L, 10000L & 12000L Tipper AquaTrans	428	4210 x 2000	\$6,940
ASFC13000	Steel Frame for 13000L, 15000L & 17000L AquaTrans™	480	5300 x 2330	\$7,785

*Disclaimer: Check compatibility with your forklift width between tynes

TransLoc™

Heavy Duty Modular Water Cartage Tanks

Heavy-Duty

Modular Water Cartage Tanks



- ✓ **Expandable** Capacity
- ✓ Modules can be plumbed to **drain independently** or **together!**
- ✓ **Low-Profile** Design
- ✓ Improved **Safety**
- ✓ 3,000L **Modules**



Free-standing design allows for mounting to flat deck truck/trailer. Unique 2 x 6" connections between modules for even filling/draining.

Fully baffled every 3,000 Litres to minimise surge (optional LiquidLocker™ baffles). Low profile design for improved safety.

InterLoc™

Fully-Drainable Chemical Tanks

Fully-Drainable

Modular Tank System



- ✓ Needing to **cart different chemicals** in one load?
- ✓ Standard with **Steel-Mounted Frame**
- ✓ Modules can be plumbed to **drain independently** or **together!**
- ✓ Fully **Baffled** (Every 2500 litres)



Needing to cart different chemicals in one load? Modules can be plumbed to drain independently or together!

Fully baffled every 2,500 Litres to minimise surge (optional LiquidLocker™ baffles). Low profile design for improved safety.



SumpTrans™

Fully-Drainable Chemical Tanks



TTi's SumpTrans™ Tank use specially blended polyethylene to handle the broadest range of liquids possible from plain water to the harshest chemicals – ask for a copy of our compatibility chart!

TTi's SumpTrans™ tanks have excellent impact resistant qualities and impervious to some of the most aggressive chemicals. SumpTrans™ incorporate the latest technology to easily handle any work environment.

Fully-Drainable Chemical Tanks

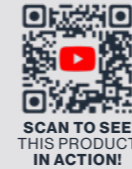

KEY FEATURES



Manufactured from chemical resistant, UV stabilised polyethylene



Large tank opening for fast, easy filling. Sealed with 455mm lid with labyrinth breather (600L+)



Easy fill, no spill containment lip on all spray tanks above 500L

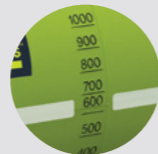

Easy to read calibrations for measurement of contents (when sight level tube fitted on tank)

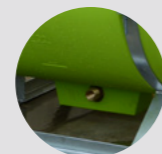

Fully draining sump with smooth interior and enables complete drainage and decontamination of tank



Available with robust hot-dip galvanised steel mounting frame for correct tank support and ease of mounting



Basket filter supplied with tanks 200 Litres and larger



SureFit™ safe and secure mounting pin system

SUMPTRANS™

Fully-Drainable Chemical Tanks

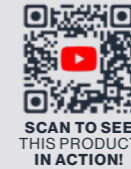

CUTAWAY

Shows Fully Draining Tank Floor

END VIEW

Shows 'V' Frame Supporting Tank



SUITABLE FOR:



POTABLE WATER



MOLASSES



CHEMICALS



VIRTUALLY ANY OTHER LIQUID!*



TANK FRAMES



All spray tanks require a steel mounting support frame to give sump clearance

TTi's steel frames are over engineered and hot dip galvanized for long lasting protection.

SUMPTRANS™

Fully-Drainable Chemical Tanks

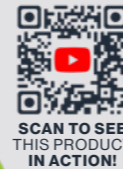

SCAN TO SEE THIS PRODUCT IN ACTION!

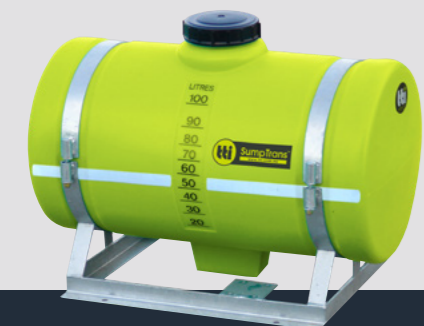

100 Litres

Tank Only	with Frame
815 x 450 x 595mm (LWH) SKU: PTSS00100SG	815 x 450 x 600mm (LWH) SKU: PTSS00100KSG
\$560*	\$955*

ø150 Lid Assembly Complete; Pair of mounting straps; 1" MBSP Fitting-Poly; Skid Frame



200 Litres

Tank Only	with Frame
940 x 600 x 750mm (LWH) SKU: PTSS00200SG	940 x 600 x 760mm (LWH) SKU: PTSS00200KSG
\$820*	\$1,135*

ø255 Filter Basket; ø255 Lid Assembly Complete; 1½" MBSP Fitting-Poly; Straps Only (pair); Skid Frame



200 Litres (Low Profile)

Tank Only	with Frame
960 x 690 x 550mm (LWH) SKU: PTSP00200SG	1085 x 700 x 600mm (LWH) SKU: PTSP00200KSG
\$835*	\$1,105*

ø255 Filter Basket; ø255 Lid Assembly Complete; ¾" MBSP Fitting-Poly; Pump Compartment Cover; Skid Frame



300 Litres

Tank Only	with Frame
1270 x 615 x 730mm (LWH) SKU: PTSS00300SG	1270 x 615 x 750mm (LWH) SKU: PTSS00300KSG
\$1,015*	\$1,380*

ø255 Filter Basket; ø255 Lid Assembly Complete; 1½" MBSP Fitting-Poly; Straps Only (pair); Skid Frame



300 Litres

Tank Only	with Frame
940 x 600 x 950mm (LWH) SKU: PTSS00300ASG	940 x 615 x 965mm (LWH) SKU: PTSS00300AKSG
\$1,015*	\$1,380*

ø255 Filter Basket; ø255 Lid Assembly Complete; 1½" MBSP Fitting-Poly; Straps Only (pair); Skid Frame



400 Litres (Low Profile)

Tank Only	with Frame
1145 x 850 x 680mm (LWH) SKU: PTSP00400SG	1230 x 850 x 710mm (LWH) SKU: PTSP00400KSG
\$1,165*	\$1,905*

ø255 Filter Basket; ø255 Lid Assembly Complete; Pump compartment cover; ¾" MBSP Fitting-Poly; 4x8x100mm BSW HED HD Bolt; 8 x 8mm washers, 4 x 8mm; nyloc nuts; Skid Frame

SUMPTRANS™

Fully-Drainable Chemical Tanks

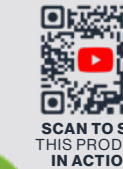

SCAN TO SEE THIS PRODUCT IN ACTION!



400 Litres

Tank Only	with Frame
890 x 820 x 960mm (LWH) SKU: PTSS00400SG	890 x 820 x 975mm (LWH) SKU: PTSS00400KSG
\$1,175*	\$1,925*

ø255 Lid Assembly Complete; ø255 Filter Basket; 1½" MBSP Fitting-Poly; Straps Only (pair); Skid Frame



500 Litres

Tank Only	with Frame
1250 x 1070 x 590mm (LWH) SKU: PTSP00500SG	1250 x 1070 x 630mm (LWH) SKU: PTSP00500KSG
\$1,315*	\$2,095*

ø255 Lid Assembly Complete; ø255 Filter Basket; 1½" MBSP Fitting-Poly; 4 Pins 18 x 200; Skid Frame



600 Litres

Tank Only	with Frame
1200 x 840 x 970mm (LWH) SKU: PTSS00600SG	1200 x 840 x 1000mm (LWH) SKU: PTSS00600KSG
\$1,325*	\$2,085*

ø255 Lid Assembly Complete; ø255 Filter Basket; 1½" MBSP Fitting-Poly; Straps Only (pair); Skid Frame



600 Litres

Tank Only	with Frame
1250 x 1070 x 750mm (LWH) SKU: PTSP00600SG	1250 x 1070 x 790mm (LWH) SKU: PTSP00600KSG
\$1,435*	\$2,300*

ø455 Lid Assembly Complete; ø455 Filter Basket; 1½" MBSP Fitting-Poly; 4 Pins 18 x 200; Skid Frame



800 Litres

Tank Only	with Frame
1430 x 1220 x 770mm (LWH) SKU: PTSP00800SG	1430 x 1220 x 800mm (LWH) SKU: PTSP00800KSG
\$1,690*	\$2,790*

ø455 Lid, Rim, & Seal Assy; ø455 Filter Basket 1½" MBSP Fitting-Poly; 4 Pins 18 x 200; Skid Frame



1,000 Litres

Tank Only	with Frame
1430 x 1220 x 940mm (LWH) SKU: PTSP01000SG	1430 x 1220 x 980mm (LWH) SKU: PTSP01000KSG
\$1,865*	\$2,975*

ø455 Lid, Rim, & Seal Assy; ø455 Filter Basket 1½" MBSP Fitting-Poly; 4 Pins 18 x 200; Skid Frame

SUMPTRANS™

Fully-Drainable Chemical Tanks

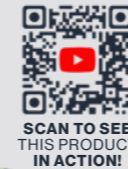

SCAN TO SEE THIS PRODUCT IN ACTION!



1,200 Litres

Tank Only	with Frame
1700 x 1200 x 950mm (LWH) SKU: PTSP01200SG	1700 x 1200 x 990mm (LWH) SKU: PTSP01200KSG
\$2,135*	\$3,425*

ø455 Lid, Rim, & Seal Assy; ø455 Filter Basket; 1½" MBSP Fitting-Poly; 4 Pins 18 x 260; Skid Frame



1,500 Litres

Tank Only	with Frame
1700 x 1200 x 1150mm (LWH) SKU: PTSP01500SG	1700 x 1200 x 1190mm (LWH) SKU: PTSP01500KSG
\$2,635*	\$4,075*

ø455 Lid, Rim, & Seal Assy; ø455 Filter Basket; 1½" MBSP Fitting-Poly; 4 Pins 18 x 260; Skid Frame



2,000 Litres

Tank Only	with Frame
2150 x 1410 x 1150mm (LWH) SKU: PTSP02000SG	2150 x 1410 x 1180mm (LWH) SKU: PTSP02000KSG
\$3,355*	\$5,210*

ø455 Lid, Rim, & Seal Assy; ø455 Filter Basket; 2" MBSP Fitting-Poly; 4 Pins 24 x 260; Skid Frame



2,400 Litres

Tank Only	with Frame
2150 x 1410 x 1310mm (LWH) SKU: PTSP02400SG	2150 x 1410 x 1360mm (LWH) SKU: PTSP02400KSG
\$3,940*	\$5,815*

ø455 Lid, Rim, & Seal Assy; ø455 Filter Basket; ø455 Lid Seal Only; 2" MBSP Fitting-Poly; 4 pins 24 x 260; Skid Frame



3,000 Litres

Tank Only	with Frame
2430 x 1540 x 1280mm (LWH) SKU: PTSP03000SG	2430 x 1540 x 1350mm (LWH) SKU: PTSP03000KSG
\$5,230*	\$8,320*

ø455 Lid, Rim, & Seal Assy; ø455 Filter Basket; ø455 Lid Seal Only; 2" MBSP Fitting-Poly; 4 pins 24 x 260; Skid Frame



4,000 Litres

Tank Only	with Frame
2430 x 1540 x 1530mm (LWH) SKU: PTSP04000SG	2430 x 1540 x 1550mm (LWH) SKU: PTSP04000KSG
\$5,905*	\$9,010*

ø455 Lid, Rim, & Seal Assy; ø455 Filter Basket; ø455 Lid Seal Only; 2" MBSP Fitting-Poly; 4 pins 24 x 260; Skid Frame

SUMPTRANS™

Fully-Drainable Chemical Tanks

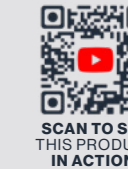

SCAN TO SEE THIS PRODUCT IN ACTION!



5,000 Litres

Tank Only	with Frame
2760 x 2000 x 1520mm (LWH) SKU: PTSP05000SG	2760 x 2000 x 1620mm (LWH) SKU: PTSP05000KSG
\$6,860*	\$10,005*

ø455 Lid, Rim, & Seal Assy; ø455 Filter Basket; ø455 Lid Seal Only; 2" MBSP Fitting-Poly; 4 pins 24 x 330; Skid Frame



6,000 Litres

Tank Only	with Frame
2760 x 2000 x 1670mm (LWH) SKU: PTSP06000SG	2760 x 2000 x 1770mm (LWH) SKU: PTSP06000KSG
\$8,585*	\$12,085*

ø455 Lid, Rim, & Seal Assy; ø455 Filter Basket; ø455 Lid Seal Only; 2" MBSP Fitting-Poly; 4 pins 24 x 330; Skid Frame



8,000 Litres

Tank Only	with Frame
3600 x 2100 x 1619mm (LWH) SKU: PTSP08000SG	3600 x 2100 x 1773mm (LWH) SKU: PTSP08000KSG
\$12,600*	\$17,400*

ø455 Lid, Rim, & Seal Assy; ø455 Filter Basket; ø455 Lid Seal Only; 2" MBSP Fitting-Poly; 6 pins 24 x 330; Skid Frame



10,000 Litres

Tank Only	with Frame
3600 x 2100 x 1960mm (LWH) SKU: PTSP10000SG	3600 x 2100 x 2114mm (LWH) SKU: PTSP10000KSG
\$14,660*	\$18,900*

ø455 Lid, Rim, & Seal Assy; ø455 Filter Basket; ø455 Lid Seal Only; 2" MBSP Fitting-Poly; 6 pins 24 x 480; Skid Frame



12,000 Litres

Tank Only	with Frame
3600 x 2100 x 2319mm (LWH) SKU: PTSP12000SG	3600 x 2100 x 2473mm (LWH) SKU: PTSP12000KSG
\$16,200*	\$20,900*

ø455 Lid, Rim, & Seal Assy; ø455 Filter Basket; ø455 Lid Seal Only; 2" MBSP Fitting-Poly; 6 pins 24 x 480; Skid Frame



13,000 Litres

Tank Only	with Frame
3480 x 2250 x 2420mm (LWH) SKU: PTSP13000SG	3480 x 2250 x 2470mm (LWH) SKU: PTSP13000KSG
\$17,615*	\$21,855*

ø455 Lid, Rim, & Seal Assy; ø455 Filter Basket; ø455 Lid Seal Only; 2" MBSP Fitting-Poly; 4 pins 24 x 480; Skid Frame

Tank Accessories



Sight Level Kit (Fitted)

\$114*

Level Kit

See Your Tank Liquid Level at a Glance

SKU: ARN001-F



3" Hydrant Fill Lid

\$1,250*

Fill Lid

Hydrant Fill System with Tilt-Lid Mechanism & 3" Top Pipe

SKU: ARH080

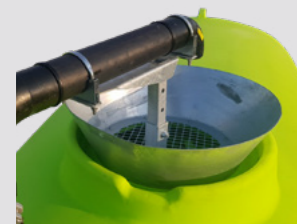

80mm Hydrant Funnel Lid

\$2,445*

Funnel Kit

Funnel Fill System with Mesh Basket & 3" Top Pipe

SKU: ARU450F

FLANGED BRASS

Tank Outlet Fittings

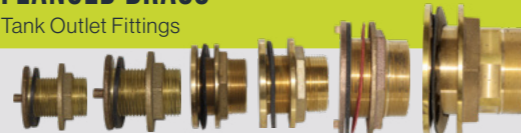

SKU	DESCRIPTION	RRP*(\$)
ARFB025	1" Brass tank outlet	\$66*
ARFB032	1¼" Brass tank outlet	\$88*
ARFB038R	1½" Brass tank outlet	\$103*
ARFB050R	2" Brass tank outlet	\$128*
ARFB080R	3" Brass tank outlet - with Reverse Thread to Prevent Loosening	\$238*
ARFB100R	4" Brass tank outlet - with Reverse Thread to Prevent Loosening	\$356*

FLANGED POLY

Tank Outlet Fittings



SKU	DESCRIPTION	RRP*(\$)
ARFP020	¾" Tank Outlet - Flanged Poly	\$20*
ARFP025	1" Tank Outlet - Flanged Poly	\$20*
ARFP032	1¼" Tank Outlet - Flanged Poly	\$23*
ARFP038	1½" Tank Outlet - Flanged Poly	\$34*
ARFP050	2" Tank Outlet - Flanged Poly	\$39*
ARFP050R	2" Tank Outlet - Reverse Thread with 2 Seals Supplied M & F Threads	\$60*

LIDS & BASKETS



SKU	DESCRIPTION	RRP*(\$)
ARLP150AV	Female Thread Tank Lid (150mm) - with Spring Breather Valve & Gasket	\$37*
ARLP250VSR	Male Thread 'Smoothe-Line Lid (255mm) - with Fixed Ring; Labyrinth Double Breather Valve	\$77*
ARLP450VSS	Screw Tank Lid (455mm) - with Rim and Seal; Fixed Labyrinth Double Breather Valve	\$135*
ARLP450VSR	Hinged Tank Lid (455mm) - with Rim and Seal 180°; with Fixed Ring; Labyrinth Breather Valve	\$135*
ARLS450VSR	450mm Stainless Steel Hinged Lid	\$580*
TTI30065	450mm Aluminium Lid	\$399*
ARK200	Basket Filter (250mm) - To suit 255mm Lid; 18# Screen 210mm ø x 235mm deep	\$63*
ARK400	Basket Filter (450mm) - To suit 455mm Lid; 18# Screen 410mm ø x 235mm deep	\$81*
LLB195	BallBaffle™ Ø195mm - 1 ball per 7 Litres	\$8*
LLB380	LiquidLocker™ Ø380mm - 1 ball per 33 Litres	\$11*



SPRAY EQUIPMENT

inter

Inter™ Knapsack & Compression Sprayers



Hand-Operated Compression Sprayers Less Pumping - More Spraying



LIGHT WEIGHT FOR EASE OF USE



- ✓ **Minimum effort** ergonomic handle
- ✓ **Large filter** with viton seals in lance handle and rustproof spring
- ✓ **Fibreglass lance** (excluding 1L)
- ✓ **Easy to use** pressurisation/carrying handle
- ✓ **Safety valve** with automatic release of excess pressure
- ✓ **Polypropylene tank**, lightweight and very strong
- ✓ **Connector** for accessories
- ✓ **Adjustable** conical nozzle



with 5-Year Warranty

		
Hand-Held Sprayer	Hand-Held Sprayer	Hand-Held Sprayer
\$49* Elite 1 Litre	\$120* Elite 5 Litres	\$154* Elite 6 Litres
SKU: PG10001L	SKU: PG10005L	SKU: PG10006L

	
Knapsack Sprayer	Knapsack Sprayer
\$242* Evo 12 Litres	\$266* Evo 16 Litres
SKU: PG10012LE	SKU: PG10016LE

Free Nozzle Kit



Featured with a Clear Liquid Level Strip

inter ACCESSORIES

Quick Fit Accessories for Maximum Spray Options

Spray Hoods

Hit your target every time without collateral damage, with the Inter Elite Spray Hoods.

	
Rectangular Hood	Conical Hood
\$54*	\$43*
SKU: ATA00B	SKU: ATA00C

Pressure Regulator

	Function 1.5 bar: Herbicide (with deflective fan nozzle)	Regulator
		\$63*
		SKU: ATA00A

	Function 3 bar Insecticide-fungicide (with hollow cone nozzle)
	
SET AND FORGET PRESSURE CONTROL	
SIMPLE TO USE ACCURATE SPRAYING TOUGH & DURABLE	

inter ACCESSORIES

Herbicide Spray Nozzles

Consistent application rates for spraying



Elbow
with Fan Nozzle

\$31*

SKU: ATA00F



L.V. Elbow
w/ Low Volume Herbicide Nozzle

\$51*

SKU: ATA00G

Evolution Lance

Complete lance to suit Inter Evo 12/16



Evolution Lance
with Fan Nozzle

\$83*

SKU: AHL011

Flexible Pipe

250mm long flexible pipe. Can be manually moulded for specialised applications.



Flexible Pipe
250mm Long

\$34*

SKU: ATA00I

Flexible Double Nozzle

Tubes can be manually moulded for specialised spraying requirements. Two models available, one with adjustable cone nozzles (H) and one with fan nozzles (HF)

Used for basal bark spraying and ant block treatments



with Adjustable Cone
460mm with 10mm Hose Tail

\$66*

SKU: ATA00HC

with Fan Nozzle
460mm with 10mm Hose Tail

\$80*

SKU: ATA00HF

Telescopic Lance

Gives your sprayer extendible length to reach hard to access areas.



Versatile Lance
460mm with 10mm Hose Tail

\$76*

SKU: AHL002T

Telescopic Lance
460mm with 10mm Hose Tail

\$117*

SKU: AHL003T

inter ACCESSORIES

Spray Booms

Three boom types to choose from to speed up your ground coverage. Lightweight for ease of use.



Extendable Double
1m Nozzle Boom

\$87*

SKU: ATA00RF



Quadruple Nozzle Boom
with Cone Spray Nozzles 1.5m

\$118*

SKU: ATA00EC

Quadruple Nozzle Boom
with Fan Spray Nozzles 1.5m

\$135*

SKU: ATA00EF

Lance Extensions

Increase your spray reach with these lightweight extensions. Ideal for reaching higher targets from the safety of the ground.



0.5m Extension

\$33*

SKU: ATA00D

1m Extension (Aluminium)

\$53*

SKU: ATA00K

1.5m Extension

\$77*

SKU: ATA00L

Seals



Seals kit for Inter 7 / 9
(159,164,165)

\$24*

SKU: CGKI0005L



Seals kit for Inter Evo 12 / 16

\$30*

SKU: CGKI0012L

IK™ INDUSTRIAL SPRAYERS

with 5-Year Warranty

These special sprayers are amongst the toughest on the market, and can be used safely in a wide variety of situations and conditions.

- ✓ Made of special, **high resistance materials** for use with various chemicals
- ✓ **Viton seals** for excellent chemical resistance and durability
- ✓ See liquid level at a glance with **tank graduations**
- ✓ **Pressure safety valve** ensures sprayer is protected from over pressurisation

WITH HEAVY-DUTY
VITON
SEALS

FOR
EXCELLENT
CHEMICAL
RESISTANCE

Ideal for:

- ✓ Truck Washing
- ✓ Brick Cleaning
- ✓ Carpet Cleaning
- ✓ Wallpaper Stripping
- ✓ Animal Husbandry
- ✓ Amenity Cleaning
- ✓ Disinfecting
- ✓ Degreasing



1L Hand-Held Sprayer

IK 1 Litre \$76*

SKU: PGK0001L



6L Hand-Held Sprayer

IK 6 Litres \$230*

SKU: PGK0006L



8L Hand-Held Sprayer

IK 8 Litres \$241*

SKU: PGK0008L



12L Knapsack Sprayer

IK 12 Litres \$299*

SKU: PGK0012L

WeedMasta™ 16R

Rechargeable Knapsack Sprayer with Trolley

- ◆ 16 Litre capacity tank, ergonomically designed for maximum carrier comfort
- ◆ Padded shoulder straps and backrest reduces user fatigue
- ◆ Spray flow rate control for spray accuracy and reduced chemical wastage
- ◆ Over two hours of continuous spraying from a rechargeable sealed lead acid 12 volt battery
- ◆ No more frustrating tangles with our kink resistant hose
- ◆ Sturdy trolley with large handle and wheels for ergonomic operation
- ◆ Reliable and effective 2.4 L/min 70psi pump for maximum spray capacity
- ◆ On-off switch control with fuse protection
- ◆ Supplied with battery charging kit



Trolley and Knapsack
Can Be Easily Separated!

*GST included | Freight Rates Apply

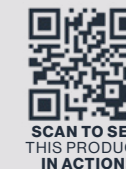

SCAN TO SEE
THIS PRODUCT
IN ACTION!

TIRED OF PUMP-UP HAND SPRAYERS?

Over 2 hours of continuous spraying from a single charge!



Pump: Speed Control

\$348*

16 Litres

Pump: Speed Control with 2.4 L/min 70psi

SKU: SVB0016L0024T



WeedControl™

SPOT SPRAYERS

Spot Sprayers with 12v Pump



Spot Sprayers with 8.3 L/min Pump & Powerjet Spray Gun.

The WeedControl™ 12v Sprayer is a reliable choice for any property owner who takes pride in keeping their property in top condition.

The WeedControl™ is designed to be mounted to UTEs, UTV's and ATVs, ensuring your spraying task gets completed safely.



SCAN TO SEE THIS PRODUCT IN ACTION!



KEY FEATURES



8.3L/min 70psi EverFlow 12v pump with Pressure regulator and gauge for controlled spraying



Sturdy UV stabilized tank with drain for easy cleaning

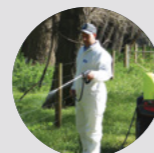

4.5m Spray hose with PowerJet spray gun & adjustable brass nozzle



2.4m electrical cables with 12v adaptor & alligator clip

WEEDCONTROL™

Spot Sprayers with 12v Pump



SCAN TO SEE THIS PRODUCT IN ACTION!



\$590*

55 Litres

12v 8.3L/min 70psi Pump with Spray Gun
865 x 390 x 345mm (LWH)

SKU: SVS0055L0077



\$690*

95 Litres

12v 8.3L/min 70psi Pump with Spray Gun
865 x 390 x 435mm (LWH)

SKU: SVS0095L0077



\$965*

150 Litres

12v 8.3L/min 70psi Pump with Spray Gun
900 x 620 x 500mm (LWH)

SKU: SVS0150L0077



\$1,190*

225 Litres

12v 8.3L/min 70psi Pump with Spray Gun
900 x 620 x 650mm (LWH)

SKU: SVS0225L0077

SKID-MOUNTED

For Side-by-Sides with 8.3L/min 70psi; 12v Pump



\$1,685*

150 Litres

\$2,070* with 4m Boom

12v 8.3L/min 70psi Pump with Spray Gun
1000 x 720 x 550mm (LWH)

SKU: SVK0150L0077 / SVK0150L0077B



\$1,925*

225 Litres

\$2,310* with 4m Boom

12v 8.3L/min 70psi Pump with Spray Gun
1000 x 720 x 750mm (LWH)

SKU: SVK0225L0077 / SVK0225L0077B

WeedControl™

12v Spray Trailers



Spot Spray Trailers with 8.3 L/min Pump & Powerjet Spray Gun.

The WeedControl™ 12v spray trailer is a reliable choice for any property owner who takes pride in keeping their property in top condition.

The WeedControl™ is designed to be towed by a standard or zero-turn mower ensuring your spraying task gets completed safely.

TRAILED



with Solid Rubber Tyres



SCAN TO SEE THIS PRODUCT IN ACTION!



STANDARD TRAILERS

Standard drawbar for smooth towing - suitable for any mower

\$1,135*

55 Litres

12v 8.3 with 2m Boom

SKU: SVT0055L0077B2

\$1,220*

95 Litres

12v 8.3 with 2m Boom

SKU: SVT0095L0077B2



ZERO-TURN TRAILERS

Long drawbar for extra-sharp turning - up to 90° - more suitable for zero-turn mowers

\$1,135*

55 Litres

12v 8.3 with 2m Boom

SKU: SVT0055L0077B2

\$1,220*

95 Litres

12v 8.3 with 2m Boom

SKU: SVT0095L0077B2



ATV TRAILERS

Large pneumatic tyres for handling rough terrain - suitable for mowers and ATV's

\$2,595*

150 Litres

12v 8.3 with 3m Boom

SKU: SVT0150L0077B3

\$2,835*

225 Litres

12v 8.3 with 3m Boom

SKU: SVT0225L0077B3

WEEDCONTROL™ BOOMS AND ACCESSORIES



SCAN TO SEE THIS PRODUCT IN ACTION!



\$197*

2 Metre Boom

2m Spray width
CODE: ABS020



\$465*

3 Metre Boom

3m Spray width
CODE: ABS030



\$545*

4 Metre Boom

4m Spray width
CODE: ABS040



\$14*

Poly 1GHT Nut

& Tail with
10mm Hosetail
SKU: ATPXP2510S



\$23*

Nozzle Body Assy Tee

10mm Barbs (2 way)
SKU: ATPNDTT10C



\$23*

Nozzle Body Assy Elbow

Pack 2 | (1 way)
SKU: ATPNDE10CX2



\$21*

Drain Cap

Complete with Seal
SKU: ATPVC20T



\$11*

Lance Clips

2 pcs of Holding Clips
SKU: CHCLP12MMX2

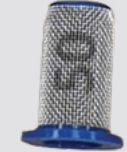

\$5*

Filter

50 Mesh Filter
SKU: 8079-PP-50



\$53*

Brown Nozzle

Deflector 140°
(Pack 10)
SKU: CNSDEF140025

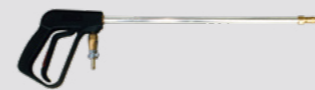

\$191*

PowerJet Spray Gun

700mm overall length
with 10mm hose tail
SKU: AHG110ST

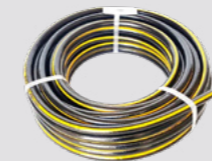

\$12/m

Spray Hose

10mm Spray Hose
SKU: CUY58010MM



\$37*

Lid

150mm Screw Lid
with Seal
SKU: ARLP150AT



\$135*

Regulator

Pressure Regulator
Assembly | QA
SKU: ATRV027LQ12



\$28*

Poppit Valve

On-Off
Valve
SKU: 34-140141



\$330*

Pump

Remco™ 12v Pump
100psi 8.3 L/min
SKU: I-11355



\$34*

Gauge

Gauge 0-100psi to
Suit SVS WeedControl
SKU: CFGD100P08B

Strike™

Professional 12v Spot Sprayers

The Strike, a sprayer that has proved itself over many years as a versatile and reliable professional 12v sprayer in our TTI range.

KEY FEATURES



8.3L/min 100psi Remco 12v pump mounted under pump cover for protection



Fully-drainable tank with a hot dip galvanised base frame



6m Spray hose with PowerJet spray gun & adjustable brass nozzle



Pressure regulator and gauge for accurate & controlled spraying



SCAN TO SEE THIS PRODUCT IN ACTION!



\$1,790* **200** Litres

1055 x 700 x 580mm (LWH)
6m Hose & Gun;
8.3L/min 100psi Pump

SKU: PVQ0200LK0076



\$2,780* **400** Litres

1200 x 800 x 700mm (LWH)
6m Hose & Gun;
8.3L/min 100psi Pump

SKU: PVQ0400LK0076

STRIKE & REELSTRIKE BOOM OPTIONS



BoomTech Nozzle

\$540*

Boom Tech Nozzle Kit with Tailgate Bracket

SKU: ABT001



HitchIt Hayman Reece Attachment; Boomless Nozzle

\$570*

HitchIt Hayman Reece Attachment; Boomless Nozzle

SKU: ABK02-GN



HitchIt Hayman Reece Attachment; Versatile Boom

\$895*

HitchIt Hayman Reece Attachment; Versatile Boom

SKU: ABVL040-GN

ReelStrike™

Professional 12v Spot Sprayers with 30m Reel

The ReelStrike™, a TTI icon sprayer that has proved itself over many years as the most versatile and reliable professional 12v sprayer in our TTI range.

The 30m reel allows you to access those "hard to get to" areas, while the 100psi pump gives you that extra pressure when you need to hit your spray target from a distance.

KEY FEATURES



8.3L/min 100psi Remco 12v pump mounted under pump cover for protection



Fully-drainable tank with a sturdy hot dip galvanised base frame



30m heavy duty poly hose reel with PowerJet spray gun



Pressure regulator and gauge for accurate & controlled spraying



SCAN TO SEE THIS PRODUCT IN ACTION!



\$2,740* **200** Litres

1055 x 700 x 1100mm (LWH)
30m Hose Reel; 8.3 L/min
100psi Pump

SKU: PVQ0200LK0076H3



\$3,880* **400** Litres

1200 x 800 x 1220mm (LWH)
30m Hose Reel; 8.3 L/min
100psi Pump

SKU: PVQ0400LK0076H3



OnDeck™

300L Purpose-Built UTV Sprayer



NEW!

Possibly the most unique and well-designed UTV Sprayer, the OnDeck™ suits the ever growing UTV market.

The 300L model comes in a clever choice of pump, motor and hose reel combinations. From weed spraying to firefighting, the OnDeck range is sure to be a valuable investment.



FULLY DRAINABLE SUMP TANK



INTEGRATED FRESH WATER TANK

ONDECK™

Purpose-Built UTV Sprayer

COMPACT
SEE PAGE 48 →

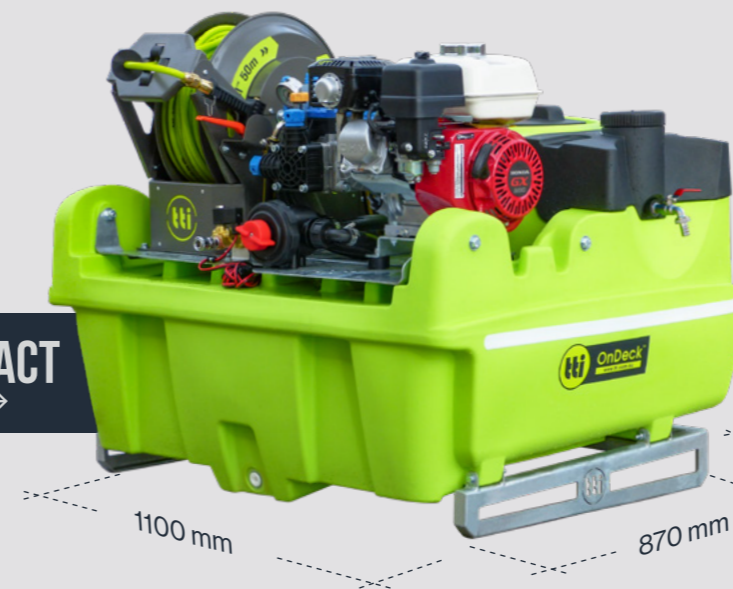

STANDARD
SEE PAGE 46 →

KEY FEATURES



Fully-drainable Tank with tie-down provisions & integrated lifting handles



Pressure regulator with gauge & bypass system



Integrated freshwater bottle & tap for hand-washing



Galvanised Forkable Steel Frame

NEW ONDECK™ TWIN SUPERREEL™

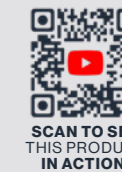

SCAN TO SEE THIS PRODUCT IN ACTION!

OnDeck™

STANDARD

Purpose-Built Sprayer for UTVs



Dim (LWH): 1000 x 1250 x 600mm

Fits UTVs including:

Kubota **LANDBOSS**

BOOM & SOLENOID OPTIONS



Boom Elec On/Off

\$323*

Solenoid Valve Kit & Pressure Relief (Fitted)

SKU: ATVS10B036F



BoomTech™ Nozzle

\$540*

Universal Stainless Steel Tailgate Mounting Bracket; Boomless Nozzle

SKU: ABT001



#2 Boomless Nozzle

\$570*

HitchIt Hayman Reece Attachment; Boomless Nozzle

SKU: ABK02-GN



4m Versatile Boom

\$895*

HitchIt Hayman Reece Attachment; Versatile Boom

SKU: ABVL040-GN

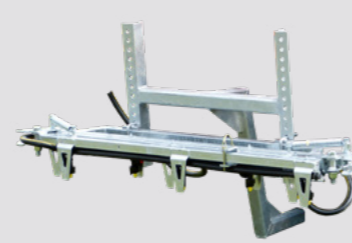

4m Compact™ Boom

\$2,135*

4m Folding Boom with Hayman Reece Attachment

SKU: ABM040-GN

STANDARD

✓ Fits UTVs including Kubota and LandBoss

✓ Dim (LWH): 1000 x 1250 x 600mm



\$3,580*

300 Litres

8.3 L/min 100psi 12v Pump
30m Hose Reel; Spray Gun

SKU: PUD0300L0076H3

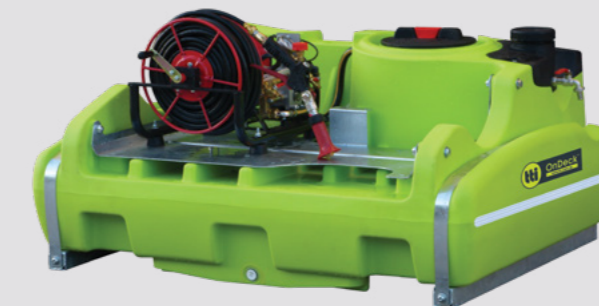

\$4,370*

300 Litres

12 L/min Pump; Honda GX35
30m Hose Reel; Spray Gun

SKU: PUD0300L0120H



\$6,735*

300 Litres

22 L/min Pump; Honda GX200
30m Hose Reel; Spray Gun

SKU: PUD0300L0220H3



\$9,620*

300 Litres

22 L/min Pump with GX200
50m Auto-Rewind SuperReel™

SKU: PUD0300L0220Q50

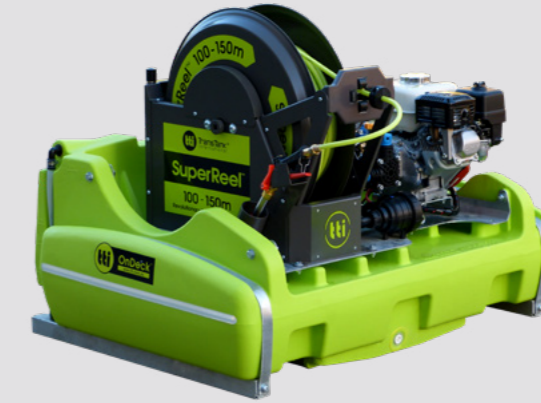

\$10,490*

300 Litres

22 L/min Pump with GX200
100m Auto-Rewind SuperReel™

SKU: PUD0300L0220Q1



SCAN TO SEE THIS PRODUCT IN ACTION!

OnDeck™

COMPACT

Purpose-Built Sprayer for UTVs



Dim (LWH): 870 x 1100 x 850mm

Fits UTVs including:



BOOM & SOLENOID OPTIONS



Boom Elec On/Off

\$323*

Solenoid Valve Kit & Pressure Relief (Fitted)

SKU: ATVS10B036F



BoomTech™ Nozzle

\$540*

Universal Stainless Steel Tailgate Mounting Bracket; Boomless Nozzle

SKU: ABT001



#2 Boomless Nozzle

\$570*

HitchIt Hayman Reece Attachment; Boomless Nozzle

SKU: ABK02-GN



4m Versatile Boom

\$895*

HitchIt Hayman Reece Attachment; Versatile Boom

SKU: ABVLO40-GN



4m Compact™ Boom

\$2,135*

4m Folding Boom with Hayman Reece Attachment

SKU: ABMO40-GN

COMPACT

✓ Fits UTVs including Polaris, Honda and Can-Am ✓ 150L (LWH): 730 x 950 x 500mm | 300L (LWH): 870 x 1100 x 850mm



\$1,910*

150 Litres

8.3 L/min 100psi 12v Pump; 6m Hose; Spray Gun

SKU: PUD0150L0076



\$2,805*

150 Litres

8.3 L/min 100psi 12v Pump; 30m Hose Reel; Spray Gun

SKU: PUD0150L0076H3



\$3,580*

300 Litres

8.3 L/min 100psi 12v Pump; 30m Hose Reel; Spray Gun

SKU: PUDA0300L0076H3



\$4,370*

300 Litres

12 L/min Pump; Honda GX35; 30m Hose Reel; Spray Gun

SKU: PUDA0300L0120H

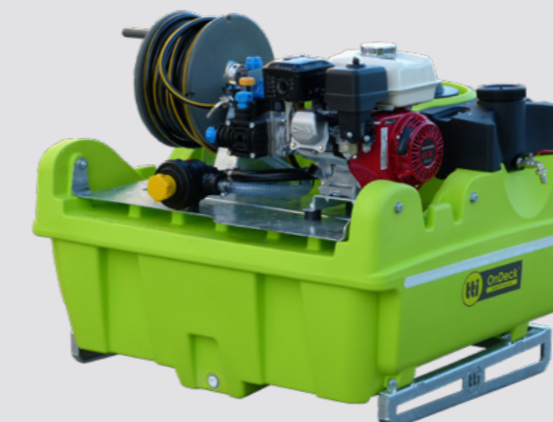

\$6,735*

300 Litres

22 L/min Pump; Honda GX200; 30m Hose Reel; Spray Gun

SKU: PUDA0300L0220H3



\$9,620*

300 Litres

22L/min Pump; Honda GX200; 50m SuperReel™

SKU: PUDA0300L0220Q50

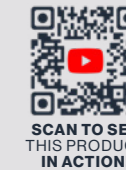

SCAN TO SEE THIS PRODUCT IN ACTION!

OnDeck™

WITH SUPERREEL™

Compact Single or Twin Reel Sprayer



Dim (LWH): 980 x 1185 x 1095mm

Fits UTVs including:



BOOM & SOLENOID OPTIONS



Boom Elec On/Off

\$ 550*

Solenoid Valve Kit & Pressure Relief (Fitted)

SKU: I-15047

BoomTech™ Nozzle

\$ 540*

Universal Stainless Steel Tailgate Mounting Bracket; Boomless Nozzle

SKU: ABT001

#2 Boomless Nozzle

\$ 570*

HitchIt Hayman Reece Attachment; Boomless Nozzle

SKU: ABK02-GN



4m Versatile Boom

\$ 895*

HitchIt Hayman Reece Attachment; Versatile Boom

SKU: ABVL040-GN

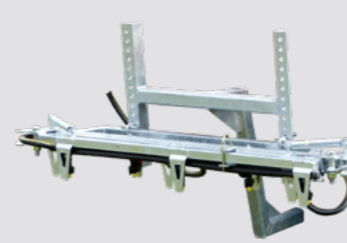

4m Compact™ Boom

\$ 2,135*

4m Folding Boom with Hayman Reece Attachment

SKU: ABM040-GN

COMPACT WITH SUPERREEL™

✓ Dim (LWH): 980 x 1185 x 1095mm

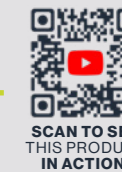

SCAN TO SEE THIS PRODUCT IN ACTION!



\$ 14,125* **300 Litres**

34 L/min Pump & GX200 Twin 50m SuperReel™

SKU: PUDT0300L0340TQ50



\$ 11,155* **300 Litres**

34 L/min Pump & GX200 Single 100m SuperReel™

SKU: PUDT0300L0340Q1



\$ 11,800* **300 Litres**

34 L/min Pump & GX200 Single 150m SuperReel™

SKU: PUDT0300L0340Q2



\$ 16,055* **300 Litres**

34 L/min Pump & GX200 Twin 100m SuperReel™

SKU: PUDT0300L0340TQ1



\$ 16,700* **300 Litres**

34 L/min Pump & GX200 Twin 150m SuperReel™

SKU: PUDT0300L0340TQ2

SpotPro™

Motorised Spot Sprayer

TTi's SpotPro™ sprayers features a powerful 360psi pump coupled to a GX35 4-stroke motor, delivering great performance out of the 30m hose reel.

KEY FEATURES



SCAN TO SEE THIS PRODUCT IN ACTION!



\$3,465*

220 Litres

925 x 710 x 910mm (LWH)

SKU: SU0220L0120H

\$4,065*

400 Litres

1620 x 710 x 910mm (LWH)

SKU: SU0400AL0120H

SPOTPRO™ & SPOTPRO™ DELUXE BOOM OPTIONS



BoomTech Nozzle

\$540*

Boom Tech Nozzle Kit with Tail Gate Bracket

SKU: ABT001



#2 Boomless Nozzle

\$570*

HitchIt Hayman Reece Attachment; Boomless Nozzle

SKU: ABK02-GN



4m Versatile Boom

\$895*

HitchIt Hayman Reece Attachment; Versatile Boom

SKU: ABVL040-GN

SpotPro™

DELUXE

Deluxe Motorised Spot Sprayer

The SpotPro™ Deluxe features a fully drainable tank for maximum use of spray mix, mounted to a forkable steel frame.

The powerful 360psi pump coupled to a GX35 4-stroke motor, delivering great performance out of the 30m hose reel. It's the preferred UTV Weed Sprayer, by many satisfied customers.

KEY FEATURES



Reliable Genuine Honda GX35 Engine



12L/min 360psi Commando Pump



30m of 8mm Hose with Reel



Adjustable Turbo Spray Gun

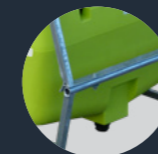

Fully-Drainable Tank with Steel Frame



Steel Skid Frame



SCAN TO SEE THIS PRODUCT IN ACTION!



\$3,700*

200 Litres

1100 x 700 x 1110mm (LWH)

SKU: PUF0200L0120H

\$4,560*

400 Litres

1200 x 800 x 1220mm (LWH)

SKU: PUF0400L0120H



TopCrop™

Professional UTE Slip-On Field Sprayer



A high performing UTE mounted field sprayer. Boasting a genuine GX200 Honda Motor, coupled to the reliable Bertolini pump, and 30m hose reel.

The forkliftable steel frame allows both easy loading and safe securing of your spray unit to your vehicle, allowing it to be put to work in minutes.



SCAN TO SEE THIS PRODUCT IN ACTION!



KEY FEATURES

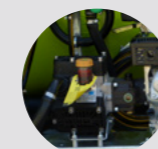

22L/min Bertolini Italian Pump



Fully-drainable Sump Tank with 455mm Hinged Lid & Basket Filter



Genuine Reliable Honda GX200



Galvanized Steel Frame with Forklift Pockets

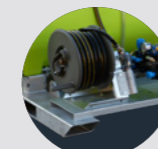

Heavy-duty 30m Hose Reel with Adjustable Pistol Grip Spray Gun

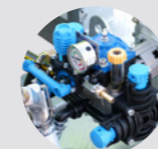

Pressure Regulator with Gauge for Controlled Spraying & Bypass Agitation System

TOPCROP™

Professional UTE Slip-On Field Sprayer



\$5,525*

300 Litres

1250 x 600 x 950mm
SKU: PUF0300L0220H3



\$7,170*

400 Litres

1489 x 970 x 1100mm
SKU: PUF0400L0220H3



\$7,300*

500 Litres

1740 x 1250 x 760mm
SKU: PUF0500L0220H3



\$7,485*

600 Litres

1740 x 1250 x 920mm
SKU: PUF0600L0220H3



\$8,090*

800 Litres

1900 x 1430 x 810mm
SKU: PUF0800L0220H3



\$8,355*

1000 Litres

1900 x 1430 x 1000mm
SKU: PUF1000L0220H3



SCAN TO SEE THIS PRODUCT IN ACTION!

Add a Compact Spray Boom!

Note: Available with 400L +

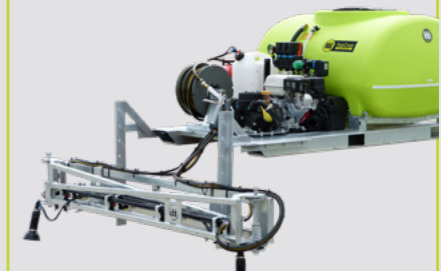

\$2,730*

4m Boom

4m Galvanised Steel with Boom Bracket Arms

\$3,356*

6m Boom

6m Galvanised Steel with Boom Bracket Arms

\$3,975*

8m Boom

8m Galvanised Steel with Boom Bracket Arms

UPGRADE!
50m SuperReel™

\$2,895*



SuperReel™

SINGLE

Field Sprayer with Single Auto-Rewind SuperReel™



The SuperReel™ slip-on field sprayer is the professionals proven choice.

The heavy-duty electric rewind reel features a powerful 120w 12v motor and is capable of winding up to 150m of hose. The FrictionFree™ nylon hose, genuine Honda engine and Bertolini pump ensures this sprayer will perform in any conditions.



SCAN TO SEE THIS PRODUCT IN ACTION!



KEY FEATURES



34L/min 580psi Bertolini Italian pump with Genuine Honda GX200 engine



Fully-Drainable Poly Tank with Forkable Galvanised Steel Frame



Single 100m 12v Auto Rewind SuperReel™ with Wireless Remote Control

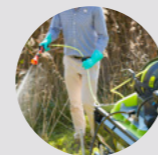

Anti-kink nylon hose with adjustable Turbo400 spray gun

Upgrade to 150m Length Reels

\$323*

SUPERREEL™

Field Sprayer with Single Auto-Rewind SuperReel™



SCAN TO SEE THIS PRODUCT IN ACTION!

SINGLE REEL



\$12,605*

400 Litres

1800 x 970 x 1000mm
SKU: PUF0400L0340Q1



\$12,820*

500 Litres

2030 x 1070 x 690mm
SKU: PUF0500L0340Q1



\$12,975*

600 Litres

1800 x 970 x 1160mm
SKU: PUF0600L0340Q1



\$12,975*

600 Litres

2030 x 1070 x 850mm
SKU: PUF0600L0340Q1



\$13,225*

800 Litres

2180 x 1220 x 870mm
SKU: PUF0800L0340Q1



\$13,635*

1000 Litres

2180 x 1220 x 1140mm
SKU: PUF1000L0340Q1

SuperReel™

TWIN

Field Sprayer with Single Auto-Rewind SuperReel™

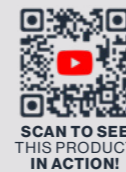

SCAN TO SEE THIS PRODUCT IN ACTION!



2-Year Warranty On Reel

KEY FEATURES



54L/min 580psi Bertolini Italian pump with Genuine Honda GX200 engine



Fully-Drainable Poly Tank with Forkable Galvanised Steel Frame



Twin 100m 12v auto rewind SuperReel's with wireless remote control

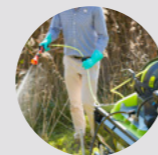

Anti-kink nylon hose with adjustable Turbo400 spray guns

Upgrade to 150m Length Reels

\$ 646*

SUPERREEL™

Field Sprayer with Twin Auto-Rewind SuperReel™

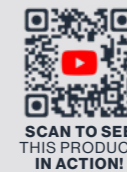

SCAN TO SEE THIS PRODUCT IN ACTION!

TWIN REEL



SHORT

\$ 20,125*

400 Litres

1800 x 1280 x 990mm (LWH)
SKU: PUF0400L0540TQ1



\$ 20,335*

500 Litres

2090 x 1300 x 832mm (LWH)
SKU: PUF0500L0540TQ1



SHORT

\$ 20,490*

600 Litres

1800 x 1280 x 990mm (LWH)
SKU: PUF0600L0540TQ1



\$ 20,490*

600 Litres

2180 x 1310 x 870mm (LWH)
SKU: PUF0600L0540TQ1



\$ 20,735*

800 Litres

2180 x 1310 x 1140mm (LWH)
SKU: PUF0800L0540TQ1



\$ 21,140*

1000 Litres

2180 x 1310 x 1140mm (LWH)
SKU: PUF1000L0540TQ1

Increase Your Spraying Efficiency with the SuperReel™ twin reel slip-on field sprayer.

The professionals proven choice, the SuperReel Sprayer with twin heavy-duty electric rewind reels are capable of winding up to 150m of hose. The FrictionFree™ nylon hose, genuine Honda engine and Bertolini pump ensures this sprayer will perform in any conditions.



TrailPro™

ATV/UTV Spray Trailer

The hitch and go convenience of the TrailPro™ trailed sprayers for ATV/UTV's, gives you the versatility of reel spraying and boom spraying from the one unit!

The 200L or 400L TrailPro™ trailer is fitted with the Honda GX200 motor, coupled to the renowned Bertolini Italian pump, so its genuine, powerful, and reliable pump and motor combination. The Standard trailer is fitted with a 8.3 L/min 100psi 12v pump which is mounted underneath a protected pump cover. Simply hitch up to your ATV or UTV and get your spraying jobs done with ease!

TrailPro™

ATV/UTV 12v Spray Trailer

The hitch and go convenience of the TrailPro 12v ATV boom spray trailer is second to none. Quiet yet powerful, the 12v TrailPro is a true pleasure to use and operate.

Compact, tough, economical, the 12v TrailPro makes for safe spraying, and gives the operator the versatility of reel spraying and boom spraying from the one unit.

KEY FEATURES



8.3L/min 100psi Remco 12v Pump Under Protected Pump Cover



Sturdy Hot Dip Galvanised Steel Chassis with High Flotation Tyres

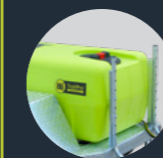

Fully-Drainable Tank with 250mm Screw Lid & Basket Filter



1.2m Versatile Boom Fitted with 4m Swath



SCAN TO SEE THIS PRODUCT IN ACTION!



\$4,970*

200 Litres

8.3 L/min 12v Pump; 6m Hose & Lance; 1.2m Versatile Boom

SKU: PRAV0200L0076-VB

\$5,865*

200 Litres with Reel

8.3 L/min 12v Pump; 1.2m Versatile Boom; 30m Hose Reel

SKU: PRAV0200L0076H3-VB



TrailPro™

DELUXE

Deluxe ATV/UTV Spray Trailer



The professionals choice, the TrailPro™ Deluxe provides unmatched performance.

The powerful GX200 Honda Engine, coupled with the Italian Bertolini 22L/min Pump, provides consistent true performance out of the spray gun or boom. The well balanced and robust design of the TrailPro handles rough terrain with ease.



SCAN TO SEE THIS PRODUCT IN ACTION!



KEY FEATURES

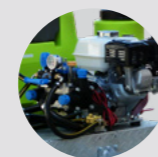

22L/min 290psi Bertolini Italian Pump with Genuine Honda GX200 Engine



Fully-Drainable Sump Tank with 250mm Screw Lid & Basket Filter



Sturdy Hot Dip Galvanised Steel Chassis with High Flotation Tyres

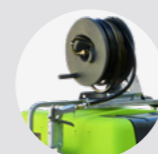

Heavy-Duty 30m Hose Reel with Adjustable Pistol Grip Spray Gun or 6m Hose

TRAILPRO™ DELUXE

Deluxe ATV/UTV Spray Trailer



Pictured with Booms



DUAL AXLE

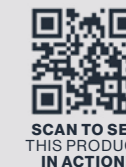

SCAN TO SEE THIS PRODUCT IN ACTION!

200 Litres

\$7,225*

with 6m Hose & Gun
SKU: PRAA0200L0220

\$7,955*

with 30m Reel
SKU: PRAA0200L0220H3

22 L/min Pump; GX200 Honda Engine; Flotation Tyres;

400 Litres

\$8,490*

with 6m Hose & Gun
SKU: PRAA0400L0220

\$9,455*

with 30m Reel
SKU: PRAA0400L0220H3

22 L/min Pump; GX200 Honda Engine; Flotation Tyres;

OPTIONS



\$650

4m Versatile Boom

1.2m Versatile Boom with 4m Swath



\$1,945*

4m Compact Boom

4m Compact Spray Break-away Boom with Non-drip Nozzles



\$2,580*

6m Compact Boom

6m Compact Spray Break-away Boom with Non-drip Nozzles



\$3,045*

Foam Marker Kit

Double Sided Foam Marker Kit with Solenoid Controls (for 6m Boom)



\$2,895*

50m SuperReel™

SuperReel™ 50m Auto-Rewind 12v Reel (Upgrade from 30m Poly Reel)

GlidePath™

Spray Trailers with Folding Boom



KEY FEATURES



Genuine Honda GX200 engine with 75L/min Bertolini Italian Pump



Fully-Drainable Poly Tank with 25-Year Warranty



Heavy-Duty Galvanised Steel Chassis with 65mm 2T-Rated Galvanised Axles



Heavy-Duty 30m Hose Reel with Adjustable Pistol Grip Spray Gun



Pressure Regulator with Gauge for Accurate & Controlled Spraying



50L Fresh Water Tank for Hand Washing

TTi's GlidePath™ Trailers are the perfect choice for farmers looking to keep weeds down and profits up.

Whether spraying weeds or fertilizer, the GlidePath™ spray trailer will get the job done on time, during the optimum small window of opportunity given.

GLIDEPATH™

Spray Trailers with Folding Boom



\$17,755* **1000 Litres**

1000L UnBraked with GX200 Honda Motor and 75L/min Pump & 3-Way Regulator

SKU: PRAX1000L0750Z



Pictured with Optional Boom

\$18,905* **1200 Litres**

1200L UnBraked with GX200 Honda Motor and 75L/min Pump & 3-Way Regulator

SKU: PRAX1200L0750Z

\$21,585* **1200 Litres**

1200L Braked / Registerable with GX200 Honda Motor 75L/min Pump & 3-Way Regulator

SKU: PRAQ1200L0750Z



SCAN TO SEE THIS PRODUCT IN ACTION!

UPGRADE OPTIONS



\$3,190*

8m Boom

Heavy-Duty Steel Boom



\$5,780*

10m Boom

Heavy-Duty Self-Leveling Steel Boom



\$5,935*

12m Boom

Heavy-Duty Self-Leveling Steel Boom



\$825*

30m Reel

30m Poly Hose Reel with Spray Gun



\$2,895*

50m SuperReel™

50m SuperReel™ Auto-Rewind Reel



\$3,045*

Foam Marker

Double Sided Deluxe Foam Marker Kit Fitted

SuperTrail™

Spray Trailers with SuperReel™ Auto-Rewind Reel

Speak to us about your specific requirements

Fitted with
Twin SuperReels™



Panther™ 1100L
New Spray Trailer

NEW!

1,000 Litres

Braked / Registerable; Single Axle Trailer;
GX200 Honda; 54 L/min 40 Bar Pump

SKU: PRAQS1000L0540TQ2

KEY FEATURES

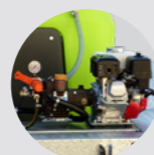

Genuine Honda GX200 Engine with 54L/min 580psi Bertolini Italian Pump

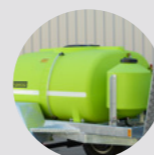

Fully-Drainable Poly Tank with 25-Year Warranty



Heavy-Duty Galvanized Steel Chassis with 65mm 2T-Rated Galvanized Axles

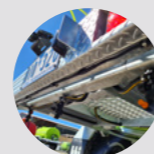

Protected 3 Nozzle Boom & Twin 100m Auto Rewind SuperReels

TTi's SuperTrail™ Trailers are the perfect choice spray trailer for councils, Landcare & environmental organisations.

Custom built to suit your requirements, the SuperTrail spray trailer will get the job done on time, even in the toughest terrain.



SilageMaster™

Silage Applicator with
Wireless Remote Control

Silage applicator kit with 100 & 200 litre spray tank, double nozzle silage boom, regulator kit & 12 volt 8.3 L/min 100psi pump & wireless remote on/off switch.

KEY FEATURES



8.3L/min 100psi
Remco 12v pump



Covers 1 metre
with 2 non-drip
nozzles
(green nozzles)



Ideal for
mounting to a
baler



Wireless remote
On/off switch for
boom activation



FREE!
WIRELESS
REMOTE

\$1,840*

100 Litres

Silage Applicator with 2 Nozzle Boom
815 x 450 x 600mm (LWH)

SKU: PJA0100L

\$1,980*

200 Litres

Silage Applicator with 2 Nozzle Boom
940 x 600 x 760mm (LWH)

SKU: PJA0200L



CUSTOM SPRAY EQUIPMENT

Call to Discuss Your Customised Spray Solutions!

CHOOSE FROM A HUGE RANGE OF SPRAY EQUIPMENT

We build spray trailers for
councils, large contractors,
mines & much more!

Give our helpful customer
service team a challenge to
build the sprayer you need!

CUSTOMISED TO YOUR REQUIREMENTS



Call to Discuss Your
Customised Spray Solutions!

1800 816 277

LinkOn™

3-Point Linkage Professional Sprayers



Hook up and go with TTI's LinkOn™ Plus Sprayer Range.

From small acreage farms to large scale operations, TTI's range of 3 point linkage boom sprayers are the perfect choice to get your boom spraying done on time using your tractor.



UV STABILISED, CHEMICAL RESISTANT TANK



HAND WASH TANK

LINKON™

3-Point Linkage Professional Sprayers



Heavy-Duty Hot Dip Galvanised Frame with Forklift Pockets



Fully-Drainable Tank with Basket Filter & 25 Year Warranty



Built-in 10L Freshwater Tank with Tap for Handwashing



22L/min or 75L/min Bertolini PTO Pump with PTO Shaft



Pressure Regulator with Gauge for Accurate & Controlled Spraying

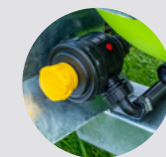

Suction Filter (Fitted)

KEY FEATURES



SCAN TO SEE THIS PRODUCT IN ACTION!



Note: Pricing below does not include the boom or hose reel



SCAN TO SEE THIS PRODUCT IN ACTION!



\$5,245* **300 Litres**

300 Litre 3-Point Linkage Complete with 22 L/min Pump, 3-way Bertolini Regulator and Gauge and PTO Shaft

SKU: PLG0300L0220



\$5,760* **400 Litres**

400 Litre 3-Point Linkage Complete with 22 L/min Pump, 3-way Bertolini Regulator and Gauge and PTO Shaft

SKU: PLG0400L0220



\$7,520* **600 Litres**

600 Litre 3-Point Linkage Complete with 75 L/min Pump, 3-way Arag Regulator and Gauge and PTO Shaft

SKU: PLG0600L0750



\$8,210*

800 Litres

800 Litre 3-Point Linkage Complete with 75 L/min Pump, 3-way Arag Regulator and Gauge and PTO shaft

SKU: PLG0800L0750



\$10,380*

1,000 Litres

1000 Litre 3-Point Linkage Complete with 75 L/min Pump, 3-way Arag Regulator with Main Elec On/Off, Gauge and PTO Shaft

SKU: PLY1000L0750CO



Scan to see this product in action!

SPEC UP YOUR LINKON™



SCAN TO SEE THIS PRODUCT IN ACTION!

SELECT YOUR BOOM



\$1,945*

4m Boom

Compact™ Steel Boom
SKU: ABM040



\$2,580*

6m Boom

Compact™ Steel Boom
SKU: ABM060

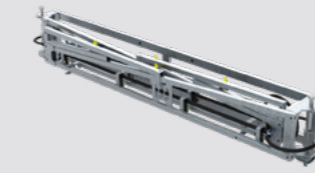

\$3,190*

8m Boom

Compact™ Steel Boom
SKU: ABM080



\$5,520*

8m Boom

Pinnacle™ Self-Leveling Steel Boom
SKU: ABM080PS

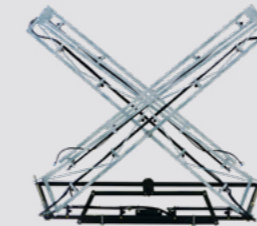

\$5,780*

10m Boom

Pinnacle™ Self-Leveling Steel Boom
SKU: ABM100PS

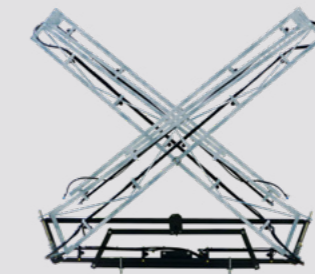

\$5,935*

12m Boom

Pinnacle™ Self-Leveling Steel Boom
SKU: ABM120PS

OTHER OPTIONS



\$865*

30m Reel

30m Poly Hose Reel with Spray Gun
SKU: ATHW03X030M106



\$3,045*

Foam Marker

Double Sided Deluxe Foam Marker Kit Fitted
SKU: ATF0024DF



\$3,605*

GPS System

TeeJet Matrix 430 Guidance System
SKU: ATCG0430



\$533*

Main Elec On/Off

Main On/Off valve with 1 way switch box (for 600L, 800L, & 1000L)



SPRAY ACCESSORIES

Pumps

Booms

Guns

Nozzles

Reels

Foam Marker Complete Kit - Double Sided

\$2,215*

SKU: ATF0024D

- Double sided deluxe model with solenoid controls
- In-cab controller** for left/right selection
- 24 Litre high strength poly tank** with safety valve
- Maximum **foam production 330 L/hr**
- Working **pressure 0.75 bar** at 12 volt DC
- Water/Foam **agent solution consumption 10.6 L/hr**
- Foam spreader** made of flexible EPDM rubber to withstand accidental impacts & more...



GPS Guidance System - Matrix 430

\$3,605*

SKU: ATCG0430

TeeJet Matrix 430

- GPS/GLONASS engine with ClearPath technology
- Easy to install and easy to operate
- Compact - install in front of the steering wheel for easy viewing during field operation
- Calculates field area, counts applied acres and produces Google Earth™ coverage maps
- Provides warning sound when entering into previously applied areas
- Cross-track error with user selectable displays for worked area, worked time & more...



GPS Guidance - Matrix 570G

\$5,955*

SKU: ATCG0570

TeeJet Matrix 570G

- The Matrix Pro GS system can be used with up to eight RealView cameras
- The Matrix Pro 570GS console features a 14.5 cm (5.7") touch screen
- A+ Azimuth (degree heading) allows identical, parallel, guidelines when operating multiple vehicles in the same field
- Field Finder organizes saved jobs according to your current GPS location
- Easy-to-use PC utility simplifies creating and maintaining client/farm/field/job data & more...



Remco 12v Pumps

TESTED | TRUSTED | CERTIFIED

- ✓ **High flow rate** with less amp draw
- ✓ **Longer duty cycle**
- ✓ **2000 Hour** life expectancy
- ✓ **12-Month Warranty**

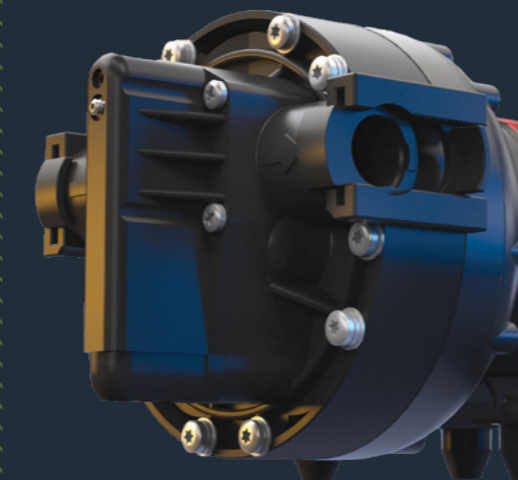

VARIANTS



\$155*

3.8 L/min 40psi

SKU: I-11805

	PSI	LMP	AMPS
OPEN	3.79	1.75	
20	2.84	2.25	
40	2.27	3.00	



\$283*

4.5 L/min 60psi

SKU: I-11353

	PSI	LMP	AMPS
OPEN	4.55	3.50	
20	3.98	4.50	
40	3.60	5.25	
60	3.03	5.50	



\$330*

8.3 L/min 100psi

SKU: I-11355

	PSI	LMP	AMPS
OPEN	8.33	2.65	
20	7.38	4.40	
40	6.06	5.80	
60	5.49	6.70	
80	5.11	7.10	
100	3.79	8.00	



\$405*

11.4 L/min 60psi

SKU: I-11347

	PSI	LMP	AMPS
OPEN	11.75	4.00	
20	8.72	6.00	
40	7.20	8.00	
60	5.50	9.50	



\$415*

15.1 L/min 100psi

SKU: I-12572

	PSI	LMP	AMPS
OPEN	17.24	4.00	
20	14.21	6.00	
40	11.56	8.00	
60	9.29	9.50	
80	8.34	10.50	
100	7.20	11.75	



\$511*

20 L/min 60psi

SKU: I-11354

	PSI	LMP	AMPS
OPEN	20.09	8.00	
20	18	11.00	
40	14.59	15.00	
60	11.37	18.00	



\$830*

26 L/min 100psi

SKU: I-11796

	PSI	LMP	AMPS
OPEN	26	11.00	
20	24	12.00	
40	20	15.00	
60	16	19.00	
80	13	23.00	
100	9	25.00	

12V PUMP PARTS & ACCESSORIES

REMCO PUMP SPARES

SKU	DESCRIPTION	RRP*(\$)
3300-PSW	Pressure switch, Remco 3300 Series 60PSI	\$37
3300-PSW-100	Pressure switch, Remco 3300 Series, 100PSI	\$61
VHA7863-7F77	Valve Housing, Remco 3300 Series	\$84
PSW-580R-60	Pressure Switch, Remco 5500 Series, 60psi	\$61
VHA5513-1X77	Valve Housing, Remco 5500 Series	\$97

DELAVAN PUMP SPARES

SKU	DESCRIPTION	RRP*(\$)
CDPLHA78607E77	Lower housing assy - for 7801 pumps; Diaphragm	\$102
CDPLHA78637F77	Lower housing assy - for 7800 pumps; Diaphragm	\$102
CDP53LHA002	Lower housing assy - for 7800 pumps; Geolast Diaphragm	\$161
CDPVHA78637F77	Valve housing assy for 7800 pumps	\$89
CDPUHA78637F77	Upper housing assy for 7800 pumps	\$89
CDPUHA78637F77T	Upper housing assy for 7812 pumps	\$89
CDP2200PSW	Pressure switch for 2200 pumps	\$26
CDP7800PSW60	Pressure switch to suit 7800 series pumps - 60psi	\$37
CDP7800PSW100	Pressure switch to suit 7800 series pumps - 100psi	\$50



SKU	DESCRIPTION	RRP*(\$)
CDP3DFE38X2	Quick Attach 10mm Elbow x 2 for 7800	\$23
CDP3DFA38X2	Quick Attach 10mm Straight x 2 for 7800	\$23
CDP5DFA38X2	Quick Attach 10mm Straight x 2 for 5900	\$30
CDP5DFE38X2	Quick Attach 10mm Elbow x 2 for 5900	\$30
CDP3DFE12X2	Quick Attach 12mm Elbow x 2 for 7800	\$23
CDP3DFA12X2	Quick Attach 12mm Straight x 2 for 7800	\$23
CDP5DFA12X2	Quick Attach 12mm Straight x 2 for 5900	\$30
CDP5DFE12X2	Quick Attach 12mm Elbow x 2 for 5900	\$30



Quick Attach Filters

- Available in 2 sizes to suit Delavan and Remco pumps
- Stainless steel mesh filter
- Simple push in & lock fitting – no tools required

SKU	DESCRIPTION	RRP*(\$)
ATPFS050Q10	Quick attach filter for 7800 pumps	\$66
ATPFS050Q12	Quick attach filter for 5900 pumps (suits Remco Pumps)	\$66



Quick Attach Regulator & Gauge

- Fitted standard to our professional spot sprayers
- Simple push in & lock fitting – no tools required
- Set & forget pressure control
- Excess fluid returns to tank & provides agitation

SKU	DESCRIPTION	RRP*(\$)
ATRM020LQ10G	Quick attach regulator & gauge for 7800 pumps	\$174
ATRM020LQ12G	Quick attach regulator & gauge for 5900 pumps (suits Remco Pumps)	\$174

Wire Harness Kit

- 3.6 metre wire harness kit with on/off switch
- Power control switch & fuse protection included
- Easy quick connect 2-pin plugs
- Kit includes both lighter adapter and alligator clips
- Max 10 Amp draw

SKU	DESCRIPTION	RRP*(\$)
ATCWL03612VSAC	Wire harness kit complete - 10 Amp	\$66



BERTOLINI DIAPHRAGM PUMPS

BERTOLINI SPARE PARTS KITS

SKU	DESCRIPTION	RRP*(\$)
CBK949879973	O-ring kit for Poly 2020	\$153
CBK949888973	SS valves kit for Poly 2020	\$160
CBK949871973	Diaphragm Kit - 20VF/RT4Poly2020 (Buna)	\$138
CBK039830973	Pump Seals Kit - PA330	\$157
CBK039850973	Valve Kit for PA330 (up to Nov 2004)	\$194
CBK039875973	Valve Kit for PA330.1 (from Dec 2004)	\$285
CBK039851973	Diaphragm Kit - PA330 (Buna)	\$138
CBK039873973	Diaphragm Kit - PA330 (Desmopan)	\$252

BERTOLINI PUMP SPARE PARTS

SKU	DESCRIPTION	RRP*(\$)
CBK639880973	Pump Seals Kit - Poly 73/2073	\$138
CBK639870973	Valve Kit - Poly 73/2073	\$455
CBK639871973	Diaphragm Kit - Poly 73/2073 (Buna)	\$180
CBK639873973	Diaphragm Kit - Poly 73/2073 (Desmopan)	\$343
CBK239880973	Valve Kit - PA530	\$327
CBK239829973	Valve Kit - PA530	\$530
CBK239828973	Buna Diaphragm Kit for PA530	\$183

Honda applied its superior engine technology to create the world's first 360° inclinable 4-Stroke engines. The ultra-lightweight GX35 Mini 4-Stroke efficiently delivers the kind of efficient cleaner, powerful, quiet performance that you'd expect from a larger engine – but in a very compact package.



Need it coupled to a **Honda GX200?** just add **\$1,465***



GX35 "Commando" **\$2,090***
12L/min Pump;
30m Reel and Gun
SKU: APP0120GH030G



22L/min Pump
2 Diaphragms; 1 3/8" Shaft; 290psi/20bar
Max Pressure; Weight: 6.6kg

\$1,350* **\$1,780***

Bare Pump & Shaft **Pump & Gear Box**
SKU: APL0220S SKU: APL0220KG



54L/min Pump
3 Diaphragms; 1 3/8" Shaft;
580psi/40bar Max Pressure

\$2,175* **\$2,785***

Bare Pump & Shaft **Pump & Gear Box**
SKU: APL0540S SKU: APL0540KG



126L/min Pump
5 Diaphragms; 1 3/8" Shaft; 218psi/15bar
Max Pressure; Weight: 12kg

\$2,360*

Bare Pump & Shaft
SKU: APL1260S



34L/min Pump
3 Diaphragms; 1 3/8" Shaft; 580psi/40bar
Max Pressure; Weight: 8.3kg

\$1,585* **\$2,195***

Bare Pump & Shaft **Pump & Gear Box**
SKU: APL0340S SKU: APL0340KG



75L/min Pump
3 Diaphragms; 1 3/8" Shaft; 218psi/15bar
Max Pressure; Weight: 11kg

\$1,740* **\$2,505***

Bare Pump & Shaft **Pump & Gear Box**
SKU: APL0750S SKU: APL0750KG



210L/min Pump
3 Diaphragms; 1 3/8" Shaft; 218psi/15bar
Max Pressure; Weight: 26kg

\$4,910*

Bare Pump & Shaft
SKU: APL2100S

SPRAY ACCESSORIES

Bertolini Regulators

- 90 L/min flow rate
- Choose from 15 bar (218psi) and 40 bar (580psi) pressure ratings
- 3 Outlets with 10mm hose tails and ball valves
- Complete with pressure gauge and mounting bracket
- Accurate and progressive pressure selection
- Reliable pressure control
- 3-way fluid control



\$600*
218psi
Sting 3-Way Regulator
90L/min, 15 bar
SKU: ATRB15B09013M3K



\$630*
580psi
Sting 3-Way Regulator
90L/min, 40 bar
SKU: ATRB40B09013M3K

Pressure Gauge **\$109*** **ADD A GAUGE!**

0-24 bar (340 psi)
SKU: CBP830010002



Arag Regulators

- Polypropylene high capacity modular system with viton seals
- Main control lever shuts off flow completely - good for boom sprays
- Manual section valves can be replaced by CA463011S electric valves to give in cab control of boom sections.
- When ordering electric controllers select switch box to suit application



\$830*

Arag Regulator
3 Manual Section Valves;
Manual On/Off
SKU: ATRA20B14013M3



\$1,755*

Arag Regulator & Gauge
3 Manual Section Valves; Elec
On/Off
SKU: ATRA20B14023M3



\$1,880*

Arag Regulator & Gauge
2 section: 2 Electric; 1 Manual
Section Valves; Electric On/Off
SKU: ATRA20B14023E2M1

Switches & Cables

The Arag compact control box is an electric device that connected to a suitable control unit allows managing all spraying stages directly inside the agricultural vehicle cabin it is installed in.

- Models with 1, 2 and 4 output sections
- Available main valve control and pressure settings adjustment



\$214*

1-Way On/Off Switch Box
SKU: ATCC1W



\$297*

2-Way On/Off Switch Box
SKU: ATCC2W



\$700*

3-Way & Main On/Off
Switch Box with Pressure
Control
SKU: ATCC3WV



\$820*

5-Way & Main On/Off Switch
Box with Pressure Control
SKU: ATCC5WVP

SPRAY ACCESSORIES

Filters

- keep your spray clear & clean!
- reduce nozzle blockage & protect your pump
- Quick attach suction filter designed to fit directly onto the female port of Delavan pumps, 80 mesh screen filter



\$66*

Suction Filter

For 7800 Series Pumps
SKU: ATPFS050Q10
For 5900 Series Pumps
SKU: ATPFS050Q12



\$66*

1/2" Suction Filter (Threaded)

To Suit Shurflo Pumps
SKU: ATPFS080T12



\$182*

1/4" Suction Filter

25mm Hosetails
SKU: ATPFSV032T32T



\$213*

1/2" Suction Filter

32mm Hosetails
SKU: ATPFSV038T38T

Boom Spray Control

Make Your Spraying Jobs Easier & Professional

- Heavy duty brass 1/2" BSP, 12VDC solenoid valves
- Suitable for most chemicals
- Viton diaphragm

Choose From 1-way or 3-way Solenoid Kits



\$323*

1-Way Solenoid Valve Kit

10 bar (140psi) 3.6m Electrical Leads 1/2" BSP Port Solenoid
SKU: ATVS10B036



\$895*

3-Way Solenoid Valve Kit

10 bar (140psi) with 3 way switch box and cables 1/2" BSP port solenoid
SKU: ATVS10BX3W

Spray Hose

SAFE
TO USE!
UP TO
40 BAR

Highly Flexible Spray Hose

Great Value Kink Resistant Hose

- High quality TTi agricultural spray hose
- High flexibility, kink resistant
- Working pressure 40 bar (580 psi)
- Burst Pressure 150 bar (2200 psi)
- Suction hose available also - call for details
- Black ribbed outer cover with a specially formulated yellow chemical resistant tube
- 10mm & 12mm hose available in 100m rolls - Call for your price

PRESSURE SPRAY HOSE

SKU	DESCRIPTION	RRP*(\$)
CUY58010MM	10mm Spray Hose (working pressure 40 bar; 580psi) / metre	\$12
CUY58010MMX10	10mm Spray Hose (working pressure 40 bar; 580psi) / 10 metre	\$96
CUY58012MM	12mm Spray Hose (working pressure 40 bar; 580psi) / metre	\$15
CUY58012MMX10	12mm Spray Hose (working pressure 40 bar; 580psi) / 10 metre	\$130
CUY58019MM	19mm Spray Hose (working pressure 40 bar; 580psi) / metre	\$31
CUY58025MM	25mm Spray Hose (working pressure 40 bar; 580psi) / metre	\$56

SUCTION HOSE

SKU	DESCRIPTION	RRP*(\$)
CUUC19MM	19mm Clear Suction Hose (not for pressure lines) / metre	\$20
STAHSB25BLK	25mm Suction Hose (not for pressure lines) / metre	\$23
STAHSB32	32mm Suction Hose (not for pressure lines) / metre	\$28
STAHSB38	38mm Suction Hose (not for pressure lines) / metre	\$30

POLY REELS

Keep your hose Neat, Tidy & Protected with a TTi Reel!

- New stronger frame design
- Reel constructed from rust-free UV stabilised poly
- NEW ReelPro - Engineered Steel Design
- Hose Reel Optimised full flow ball bearing swivel - easier rewinding under pressure
- New positive reel locking device works in four positions to prevent hose unwinding in transit



\$865*

30m Reel & Hose

Base Mount - 10mm Hose & Free Spray Gun
SKU: ATHW03B030M10G

\$865*

30m Reel & Hose

Side Mount - 30m Hose Reel w/ 10mm Hose & Free Spray Gun
SKU: ATHW03X030M10G

\$1,585*

100m Hose & Reel

Base Mount - for 10mm Hose and Spray Gun
SKU: ATHW10B100M10G

SuperReel™

Remote Controlled Rewind Hose Reel

Designed to perform in the toughest terrain, the remote controlled SuperReel™ spray reels are guaranteed to make the job quick, easy and safe for any operator.

- Powerful belt-driven 12v motor. Geared reduction for maximum torque and power efficiency
- 100m or 150m 10mm ID anti-kink nylon hose
- Hose roller guide allows for one-person operation, from any angle
- Manual override button for powered retraction, without the remote control
- Easy bolt-down points with tough powder-coated finish
- Wireless remote transmits up to 200m in uneven terrain!
- Interchangeable left/right spray gun holder
- Turbo 400 spray gun (optional accessory)



\$3,760*

50m

Auto-Rewind Reel
600 x 355 x 450mm (LWH)
SKU: ATHR050M10-R



\$5,135*

100m

Auto-Rewind Reel
810 x 355 x 675mm (LWH)
SKU: ATHR100M10



\$5,515*

150m

Auto-Rewind Reel
810 x 355 x 675mm (LWH)
SKU: ATHR150M10

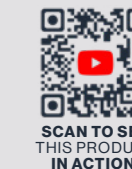

SCAN TO SEE
THIS PRODUCT
IN ACTION!

SPRAY ACCESSORIES - HOME GARDEN SPRAY LANCES

Add any of these to your versatile or telescopic lances

Versatile Lance

- Lightweight all-purpose lance
- Virtually unbreakable shaft
- Adjustable spray nozzle
- Overall length: 760mm
- Maximum pressure: 10 bar
- Choose from a large range of compatible accessories
- 10mm hosetail



\$76*

Versatile Lance

with 10mm Hose Tail
SKU: AHL002T



\$17*

Nozzle Replacement

SKU: CGP726

Economy Lance

- Lightweight chromed aluminium
- Adjustable spray nozzle
- Filter in handle
- 10mm hose barb connection
- 850mm overall length

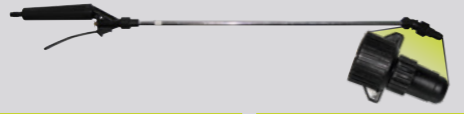

\$51*

Economy Lance

with 10mm Hose Barb
Length: 850mm
SKU: AHL009



\$16*

Nozzle Replacement

SKU: CPLP009N

Telescopic Lance

- Lightweight lance with long reach for trees and bushes
- Very easily adjusted
- Maximum pressure: 10 bar (145 psi)
- Overall length: from 710 to 1150mm
- Compatible with Inter accessories as shown
- 10mm hosetail

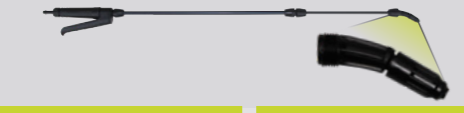

\$117*

Telescopic Lance

with 10mm Hose Tail
Length: 760mm
SKU: AHL003T



\$17*

Nozzle Replacement

SKU: CGP726

Spray Booms

- Three boom types to choose from to speed up your ground coverage.
- Lightweight for ease of use.



\$87*

Telescopic Lance

Nozzle Boom
SKU: ATA00RF



\$118* / \$135*

Quadruple Nozzle Boom

with Cone/Fan Spray Nozzles 1.5m
SKU: ATA00EC (CONE) / ATA00EF (FAN)

Spray Hoods

- Hit your target every time without collateral damage, with the Inter Elite Spray Hoods.



\$43*

Conical Hood

SKU: ATA00C



\$54*

Rectangular Hood

SKU: ATA00B

Herbicide Nozzles

- Consistent application rates for band spraying



\$51*

Elbow

With low volume

SKU: ATA00G



\$31*

Elbow

with fan nozzle

SKU: ATA00F

Spray Hoods

Tubes can be manually moulded for specialised spraying requirements.

Two models available, one with adjustable cone nozzles and one with fan nozzles.

Used for basal bark spraying and ant block treatments.



\$66* / \$80*

Flexible Double Nozzle

Adjustable Cone/Fan Spray Nozzles

SKU: ATA00HC (CONE) / ATA00HF (FAN)

SPRAY ACCESSORIES - SPRAY GUNS

Heavy Duty Pistol Grip

- All metal construction – stainless steel, aluminium & brass
- High pressure, long range spray gun
- Teflon seal
- Overall Length: 180mm
- Easily adjustable spray pattern
- Max. pressure: 55 bar (800psi)
- Max. flow: 15 L/min (580psi) with 3mm nozzle



\$261*

Pistol Grip Spray Gun

SKU: AHG104ST

KITS

REPAIR KIT - CPLK104R NUT & WASHER

FOR NOZZLE - CPLP104N
1.5MM NOZZLE - CPLP104N15
2.0MM NOZZLE - CPLP104N20
2.5MM NOZZLE - CPLP104N25
3.0MM NOZZLE - CPLP104N30
3.5MM NOZZLE - CPLP104N35
4.0MM NOZZLE - CPLP104N40

Spot 300 Lance

- Heavy Duty Spot Spray Gun
- Trigger adjustable spray pattern with lock
- Max pressure: 40 bar (580psi)
- Overall length: 300mm



\$269*

Spot 300 Lance

SKU: AHG105ST

KITS

REPAIR KIT - CPLK105R NUT & WASHER

5MM NOZZLE - CPLP105N15
2.3MM NOZZLE - CPLP105N23

Top Gun

- High pressure, long range, multipurpose spray gun
- Front handgrip allows quick spray pattern selection
- Fitted with trigger lock and 1/2" swivel inlet
- Overall length: 700mm
- Max range: 25m @ 50bar
- Max pressure: 60 bar (870psi)
- Max flow rate: 135 L/min



\$397*

Top Gun

SKU: AHG107ST

KITS

REPAIR KIT - CPLK107R 2.3MM NOZZLE - CPLP107N23

KEEP YOUR PLANTS SAFE!

Add a Spray Hood for Target Spraying

\$92*

Rectangular Spray Shield Kit

SKU: ATPS001



Rectangular Spray Shield Kit to suit Powerjet Spray Gun

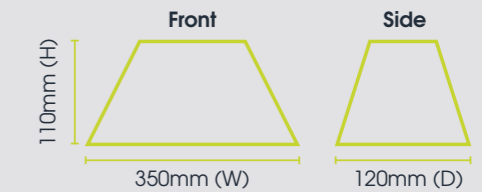

SPRAY ACCESSORIES - SPRAY GUNS

PowerJet Spray Guns

Simple & effective operating system using stainless steel ball & seat & brass housing

- ◆ Durable, dependable spray gun for all spraying applications
- ◆ Adjustable spray nozzle
- ◆ Maximum pressure: 20Bar 300psi
- ◆ Fitted with hose swivel

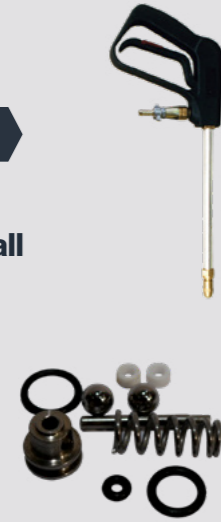

\$191*
Regular Lance
Overall length: 475mm
SKU: AHG109ST

\$37*
Repair Kit PowerJet
SKU: CPLK108R



\$191*
Standard Lance
Overall length: 700mm with 10mm Hose Tail
SKU: AHG110ST



\$218*
Long Lance
Overall length: 840mm with 10mm Hose Tail
SKU: AHG111ST

SKU: CPLP108N
High Quality Brass Adjustable Nozzle
\$32*

RapidJet Spray Gun

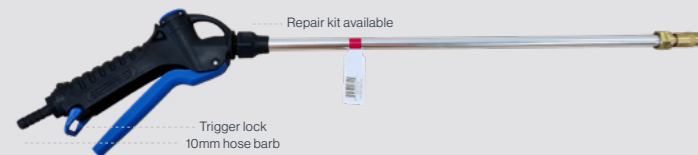

- ◆ Ergonomic spray gun with long reach
- ◆ Easily adjustable brass nozzle for a variety of spray patterns
- ◆ Maximum pressure: 17 bar (250 psi)
- ◆ Max. flow rate: 26 L/min
- ◆ Overall length: 740mm
- ◆ 10mm hose barb

\$129*
RapidJet Spray Gun
SKU: AHG112T

Turbo Spray Gun



- ◆ Great value multipurpose spray gun
- ◆ One hand operation for easy pattern adjustment + on/off trigger
- ◆ Adjustable turbo atomiser
- ◆ Supplied with 10mm hose tail
- ◆ Max pressure 360psi
- ◆ Overall length 445mm

\$129*
Turbo Spray Gun
SKU: AHG101T

KITS

REPAIR KIT
SKU: CPLK102R
2.3MM CERAMIC NOZZLE
SKU: CPLP102N23
3.5MM CERAMIC NOZZLE
SKU: CPLP102N35

FREE!

Turbo Spray Guns Comes with 10mm Hose Tail

SPRAY ACCESSORIES - SPRAY GUNS

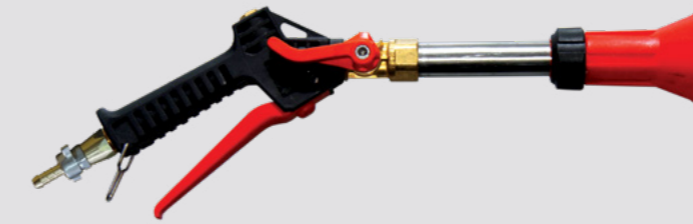

Turbo 400 Spray Gun

- ◆ Professional multipurpose spray gun with Viton seals
- ◆ One hand operation for easy pattern adjustment and on/off trigger
- ◆ Adjustable turbo atomiser
- ◆ Comes with swivel & 10mm hose tail
- ◆ Max pressure: 50 bar (725psi)
- ◆ Overall length: 400mm

\$213*
Turbo 400 Spray Gun
SKU: AHG102ST

KITS

REPAIR KIT
SKU: CPLK102R
2.3MM CERAMIC NOZZLE
SKU: CPLP102N23
3.5MM CERAMIC NOZZLE
SKU: CPLP102N35

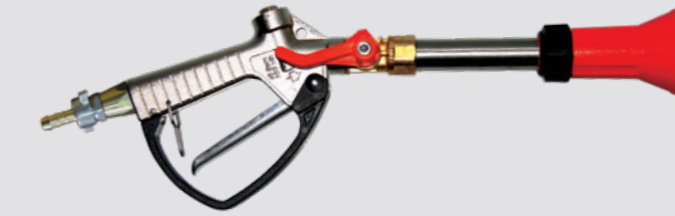

Multi-Purpose Spray Gun

- ◆ Professional multipurpose high pressure spray gun with Viton seals
- ◆ Adjustable turbo atomiser for full range of spray requirements from straight stream to soft atomised cone spray position
- ◆ Metal handle & trigger guard favoured by many operators
- ◆ Swivel & 10mm hose tail supplied
- ◆ Max pressure: 50 bar (725psi)
- ◆ Overall length: 400mm

\$253*
Multi-Purpose Spray Gun
SKU: AHG103ST

KITS

REPAIR KIT
SKU: CPLK102R



SPRAY ACCESSORIES - SPRAY BOOMS

For Firebreaks, Rough Country Spraying & Locust Control

Brass Boomless Nozzle Kits

Ideal for Blanket Spraying



FEATURES

- 4 sizes to choose from
- Use with ATV, 3PL or ute sprayers
- Can be used as 180° swath or 90° swath by swapping nozzle plates
- Ideal for rough country spraying & locust control
- Optimum mounting height between 0.5m & 1.0m above ground



\$234*	\$303*
7m (37L/hect)	16m (147L/hect)
7m Spray Width Minimum Pump Capacity 7L/min SKU: ABK02	16m Spray Width Minimum pump capacity 20 L/min SKU: ABK10

\$247*	\$329*
15m (74L/hect)	17m (190L/hect)
15m Spray Width Minimum pump capacity 11L/min SKU: ABK05	17m Spray Width Minimum pump capacity 30 L/min SKU: ABK20



\$313*
Mounting Bracket
Goose Neck (Only)
Fits any 50mm Haymen Reese Tow Hitch; Compatible with Boomless Nozzle

BoomJet™ Nozzle

Boomless Brass Nozzle



\$705*
BoomJet
Boomless Brass Nozzle;
0.91kg
SKU: SEE TABLE

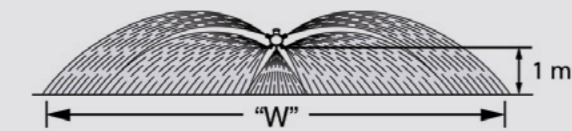

BoomJet NOZZLES W = Maximum effective coverage with nozzle mounted at 1m height

	(2)	(2)	(1)	bar	l/min	"W" (meters)
ABJ006	6733-OC06	H1/4VV-1506	H1/4VVL-9502 with 50 mesh strainer	1.5 2.0 2.5	7.26 8.38 9.37	10.2 10.3 10.5
ABJ010	OC10	H1/4U-0508HE	H1/4VVL-11004 with 50 mesh strainer	1.5 2.0 2.5	11.16 12.89 14.41	12.0 12.1 12.3
ABJ020	OC20	H1/4U-0520HE	H1/4VVL-9506 with 50 mesh strainer	1.5 2.0 2.5	24.00 27.72 30.99	14.3 15.2 15.8
ABJ040	OC40	H1/4U-0540HE	H1/4U-9510	1.5 2.0 2.5	47.44 54.78 61.25	17.1 18.2 19.2

Notes: Always double check your application rates. Tabulations are based on spraying water at 70°F (21°C).

BoomTech™ Nozzle

Tail Gate Mounted Nozzle Kit

\$540*
BoomTech
BoomTech Nozzle Kit
SKU: ABT001



- Universal Stainless Steel Tailgate Mounting Bracket
- Ideal for fence lines, orchard, blanket and end row spraying
- Excellent Drift Control
- Min Pump Capacity Required: 11.4L/min
- Recommended spray pressure range: 20-60 PSI (1.5-4 bar)

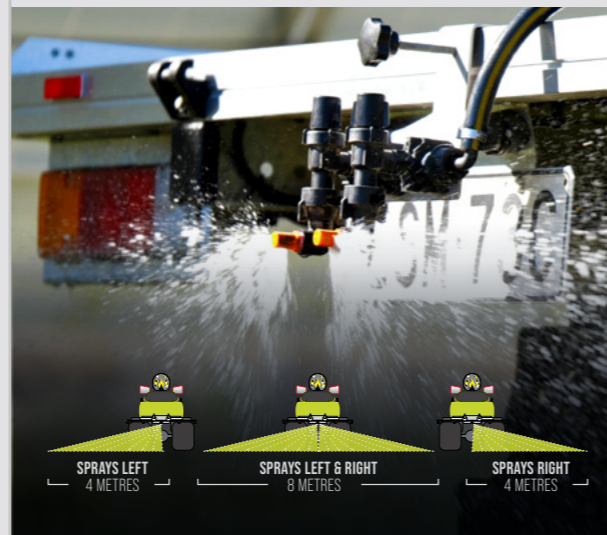

SPRAYS LEFT 4 METRES | SPRAYS LEFT & RIGHT 8 METRES | SPRAYS RIGHT 4 METRES

SPRAY ACCESSORIES - SPRAY BOOMS

Versatile Boom

- 1.2 metre compact boom
- Sprays 4 metre swath width
- Compatible with any spot sprayer with pump - 6.5 L/min or more
- Taps for 7-way nozzle control
- Versatility of spraying options



\$650*
4m Boom
Sprays up to 4 metres
SKU: ABVL040



\$895*
4m Boom
Haymen Reese Goose neck attachment with Versatile Boom
SKU: ABVL040-GN

Economy Booms



\$197*
2 Metre Boom
2m Spray width
SKU: ABS020



\$465*
3 Metre Boom
3m Spray width
SKU: ABS030



\$545*
4 Metre Boom
4m Spray width
SKU: ABS040

Versatile Boom Spray Selections



Compact™

Compact Galvanised Spray Boom



NEW & IMPROVED DESIGN

- ✓ Very easy to fold/unfold for spraying and traveling positions
- ✓ Spring-loaded breakaway with nozzle protection
- ✓ Non-drip nozzle bodies with Teejet AIXR Air Induction spray tips
- ✓ Easy to mount onto your existing sprayer!

Fitted with TeeJet Air Induction Nozzles



\$1,945*
4m Boom
Galvanised Boom with Nozzle Protection
SKU: ABM040

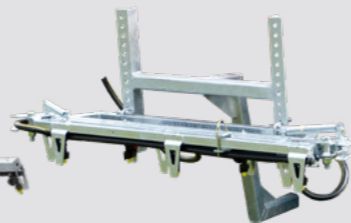

\$2,135*
4m Boom with Goose Neck
4m Folding Boom with Hayman Reece Attachment
SKU: ABM040-GN



\$2,580*
6m Boom
Galvanised Boom with Nozzle Protection
SKU: ABM060

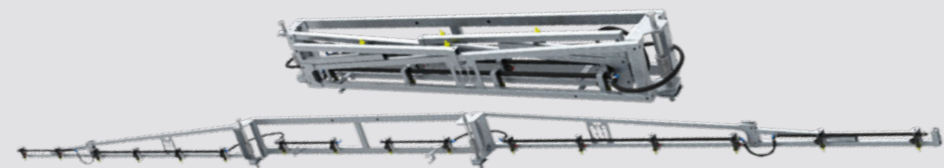

\$3,190*
8m Boom
Galvanised Boom with Nozzle Protection
SKU: ABM080

Pinnacle™ 'Plus'

Galvanised Spray Boom with Self Level



- ✓ Self-levelling booms allows boom to ride smoothly over uneven terrain
- ✓ Breakaway boom with nozzle protection
- ✓ Non drip nozzle bodies with Teejet AIXR Air Induction spray tips
- ✓ Easy to mount onto your existing sprayer!
- ✓ Hot dipped galvanised steel framework
- ✓ Optional upgrade to Tri-nozzle bodies



\$5,520*
8m Boom
Galvanised Boom with Self-levelling Kit
SKU: ABM080PS

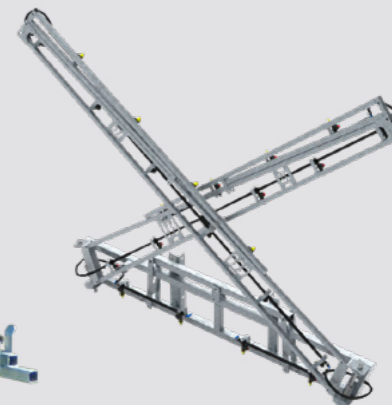

\$5,780*
10m Boom
Galvanised Boom with Self-levelling Kit
SKU: ABM100PS



\$5,935*
12m Boom
Galvanised Boom with Self-levelling Kit
SKU: ABM120PS

XR

Air Induction



Flat Spray Tips

110° wide, tapered flat spray angle with air induction technology offers better drift management

Made of a **two piece UHMWPE polymer construction with VisiFlo®** colour-coding. UHMWPE provides excellent chemical resistance, including acids, exceptional wear life

Depending on the chemical, produces large air-filled drops through a **Venturi air aspirator**

Available in **seven tip capacities** with a wide operating pressure range: **15–90 PSI** (1–6 bar)

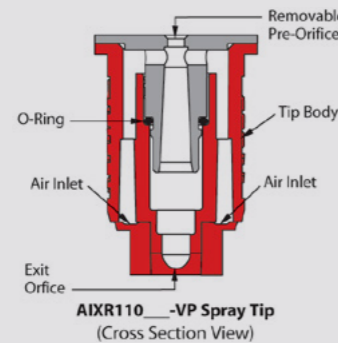

SKU	DESCRIPTION	COLOUR	RRP*(\$)
CNSAIXR110015X10	Air induction XR Flat Spray Tips (PACK of 10)		\$ 191*
CNSAIXR110020X10			\$ 191*
CNSAIXR110025X10			\$ 191*
CNSAIXR110030X10			\$ 191*
CNSAIXR110040X10			\$ 191*
CNSAIXR110050X10			\$ 191*
CNSAIXR110060X10			\$ 191*

TIPOLOGY	bar	DROP SIZE	CAPACITY ONE NOZZLE IN l/min	l/ha Δ 50cm												
				4 km/h	5 km/h	6 km/h	7 km/h	8 km/h	10 km/h	12 km/h	16 km/h	18 km/h	20 km/h	25 km/h	30 km/h	35 km/h
AIXR110015 (100)	1.0	XC	0.34	102	81.6	68.0	58.3	51.0	40.8	34.0	25.5	22.7	20.4	16.3	13.6	11.7
	2.0	VC	0.48	144	115	96.0	82.3	72.0	57.6	48.0	36.0	32.0	28.8	23.0	19.2	16.5
	3.0	C	0.59	177	142	118	101	88.5	70.8	59.0	44.3	39.3	35.4	28.3	23.6	20.2
	4.0	C	0.68	204	163	136	117	102	81.6	68.0	51.0	45.3	40.8	32.6	27.2	23.3
	5.0	M	0.76	228	182	152	130	114	91.2	76.0	57.0	50.7	45.6	36.5	30.4	26.1
6.0	M	0.83	249	199	166	142	125	99.6	83.0	62.3	55.3	49.8	39.8	33.2	28.5	
AIXR11002 (50)	1.0	XC	0.46	138	110	92.0	78.9	69.0	55.2	46.0	34.5	30.7	27.6	22.1	18.4	15.8
	2.0	VC	0.65	195	156	130	111	97.5	78.0	65.0	48.8	43.3	39.0	31.2	26.0	22.3
	3.0	C	0.79	237	190	158	135	119	94.8	79.0	59.3	52.7	47.4	37.9	31.6	27.1
	4.0	C	0.91	273	218	182	156	137	109	91.0	68.3	60.7	54.6	43.7	36.4	31.2
	5.0	C	1.02	306	245	204	175	153	122	102	76.5	68.0	61.2	49.0	40.8	35.0
6.0	M	1.12	336	269	224	192	168	134	112	84.0	74.7	67.2	53.8	44.8	38.4	
AIXR110025 (50)	1.0	XC	0.57	171	137	114	97.7	85.5	68.4	57.0	42.8	38.0	34.2	27.4	22.8	19.5
	2.0	XC	0.81	243	194	162	139	122	97.2	81.0	60.8	54.0	48.6	38.9	32.4	27.8
	3.0	VC	0.99	297	238	198	170	149	119	99.0	74.3	66.0	59.4	47.5	39.6	33.9
	4.0	C	1.14	342	274	228	195	171	137	114	85.5	76.0	68.4	54.7	45.6	39.1
	5.0	C	1.28	384	307	256	219	192	154	128	96.0	85.3	76.8	61.4	51.2	43.9
6.0	C	1.40	420	336	280	240	210	168	140	105	93.3	84.0	67.2	56.0	48.0	
AIXR11003 (50)	1.0	XC	0.68	204	163	136	117	102	81.6	68.0	51.0	45.3	40.8	32.6	27.2	23.3
	2.0	XC	0.96	288	230	192	165	144	115	96.0	72.0	64.0	57.6	46.1	38.4	32.9
	3.0	VC	1.18	354	283	236	202	177	142	118	88.5	78.7	70.8	56.6	47.2	40.5
	4.0	C	1.36	408	326	272	233	204	163	136	102	90.7	81.6	65.3	54.4	46.6
	5.0	C	1.52	456	365	304	261	228	182	152	114	101	91.2	73.0	60.8	52.1
6.0	C	1.67	501	401	334	286	251	200	167	125	111	100	80.2	66.8	57.3	
AIXR11004 (50)	1.0	XC	0.91	273	218	182	156	137	109	91.0	68.3	60.7	54.6	43.7	36.4	31.2
	2.0	XC	1.29	387	310	258	221	194	155	129	96.8	86.0	77.4	61.9	51.6	44.2
	3.0	VC	1.58	474	379	316	271	237	190	158	119	105	94.8	75.8	63.2	54.2
	4.0	VC	1.82	546	437	364	312	273	218	182	137	121	109	87.4	72.8	62.4
	5.0	C	2.04	612	490	408	350	306	245	204	153	136	122	97.9	81.6	69.9
6.0	C	2.23	669	535	446	382	335	268	223	167	149	134	107	89.2	76.5	
AIXR11005 (50)	1.0	XC	1.14	342	274	228	195	171	137	114	85.5	76.0	68.4	54.7	45.6	39.1
	2.0	XC	1.61	483	386	322	276	242	193	161	121	107	96.6	77.3	64.4	55.2
	3.0	XC	1.97	591	473	394	338	296	236	197	148	131	118	94.6	78.8	67.5
	4.0	VC	2.27	681	545	454	389	341	272	227	170	151	136	109	90.8	77.8
	5.0	C	2.54	762	610	508	435	381	305	254	191	169	152	122	102	87.1
6.0	C	2.79	837	670	558	478	419	335	279	209	186	167	134	112	95.7	
AIXR11006 (50)	1.0	XC	1.37	411	329	274	235	206	164	137	103	91.3	82.2	65.8	54.8	47.0
	2.0	XC	1.94	582	466	388	333	291	233	194	146	129	116	93.1	77.6	66.5
	3.0	XC	2.37	711	569	474	406	356	284	237	178	158	142	114	94.8	81.3
	4.0	VC	2.74	822	658	548	470	411	329	274	206	183	164	132	110	93.9
	5.0	C	3.06	918	734	612	525	459	367	306	230	204	184	147	122	105
6.0	C	3.35	1005	804	670	574	503	402	335	251	223	201	161	134	115	

Note: Always double check your application rates. Tabulations are based on spraying water at 70°F (21°C).



VISIFLO

Air Induction

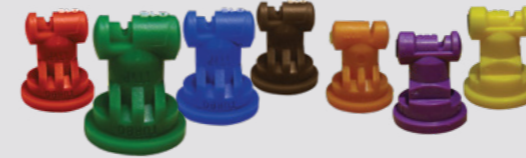

Angle Flat Spray Tips

Tapered edge wide angle flat spray pattern for uniform coverage in broadcast spraying Large, rounded internal passage to minimize clogging

Excellent resistance to corrosive solutions

Superior wear characteristics

Larger droplets for less drift; **15–90 PSI** (1–6 bar)

Applications

Herbicides, fungicides and insecticides

SKU	DESCRIPTION	COLOUR	RRP*(\$)
CNSTT110010X10	Turbo TeeJet Angle Flat Spray Tips (PACK of 10)		\$ 174*
CNSTT110015X10			\$ 174*
CNSTT110020X10			\$ 174*
CNSTT110025X10			\$ 174*
CNSTT110030X10			\$ 174*
CNSTT110040X10			\$ 174*
CNSTT110050X10			\$ 174*
CNSTT110060X10		\$ 174*	
CNSTT110080X10		\$ 174*	

TURBO

2, 4 - D Compliant



Twin Flat Spray Tips

110° wide angle, air induction, tapered flat spray tip pattern based on the patented outlet orifice design of the original Turbo TeeJet® nozzle

Patented orifice design provides large, round passages to minimize plugging.

Depending on the chemical, produces large air-filled drops through a Venturi air aspirator resulting in less drift

Applications

Herbicides, fungicides and insecticides

SKU	DESCRIPTION	COLOUR	RRP*(\$)
TTI110015-VPX10	Turbo TeeJet (PACK of 10)		\$ 225*
TTI11002-VPX10			\$ 225*
TTI110025-VPX10			\$ 225*
TTI11003-VPX10			\$ 225*
TTI11004-VPX10			\$ 225*

TIPOLOGY	bar	DROP SIZE	CAPACITY ONE NOZZLE IN l/min
TT11001 (100)	1.0	C	0.23
	2.0	M	0.32
	3.0	F	0.39
	4.0	F	0.45
	5.0	F	0.50
6.0	F	0.55	
TT110015 (100)	1.0	C	0.34
	2.0	M	0.48
	3.0	M	0.59
	4.0	M	0.68
	5.0	F	0.76
6.0	F	0.83	
TT11002 (50)	1.0	C	0.46
	2.0	C	0.65
	3.0	M	0.79
	4.0	M	0.91
	5.0	M	1.02
6.0	F	1.12	
TT110025 (50)	1.0	VC	0.57
	2.0	C	0.81
	3.0	M	0.99
	4.0	M	1.14
	5.0	M	1.28
6.0	M	1.40	
TT11003 (50)	1.0	VC	0.68
	2.0	C	0.96
	3.0	C	1.18
	4.0	M	1.36
	5.0	M	1.52
6.0	M	1.67	
TT11004 (50)	1.0	XC	0.91
	2.0	C	1.29
	3.0	C	1.58
	4.0	C	1.82
	5.0	M	2.04
6.0	M	2.23	
TT11005 (50)	1.0	XC	1.14
	2.0	VC	1.61
	3.0	C	1.97
	4.0	C	2.27
	5.0	C	2.54
6.0	M	2.79	
TT11006 (50)	1.0	XC	1.37
	2.0	VC	1.94
	3.0	C	2.37
	4.0	C	2.74
	5.0	C	3.06
6.0	M	3.35	
TT11008 (50)	1.0	XC	1.82
	2.0	VC	2.58
	3.0	C	3.16
	4.0	C	3.65
	5.0	C	4.08
6.0	M	4.47	

TIPOLOGY	PSI	DROP SIZE	CAPACITY ONE NOZZLE IN GPM	CAPACITY ONE NOZZLE IN OZ./MIN.
TT110015 (100)	15	UC	0.092	12
	20	UC	0.11	14
	30	UC	0.13	17
	40	UC	0.15	19
	50	UC	0.17	22
TT11002 (50)	15	UC	0.12	15
	20	UC	0.14	18
	30	UC	0.17	22
	40	UC	0.20	26
	50			



DIESEL

REFUELING EQUIPMENT

DieselSergeant™

Low-Profile Diesel Refueling Units

The Reason to Say GoodBye to Jerry Cans!

The low-profile, compact DieselSergeant™ is a simple yet effective diesel refueling tank. The pump is mounted on a sturdy 'squat' tank, with a large lid for easy access to the tank.

Pin-mounting provisions make it easy to secure to tank for safe transportation.

KEY FEATURES

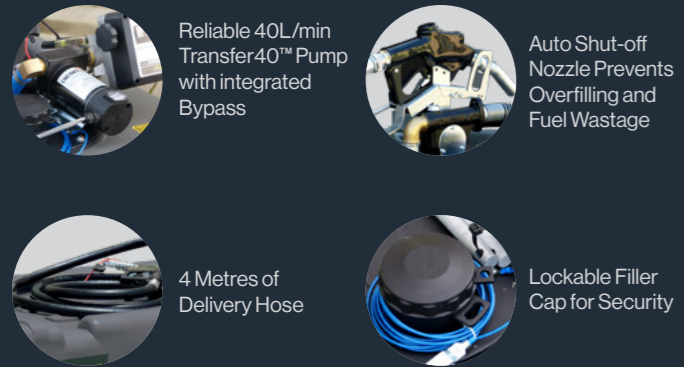

Fits Where Others Don't!
Low Profile, Space Saver Design



40L/min Pump	
\$1,430*	\$1,660*
220 Litres	400 Litres

SKU: DSU0220LD040V1

SKU: DSU0400ALD040V1



DieselMajor™

with Honda GX50 Petrol Pump

The DieselMajor™ lives up to its name, as the big boy of portable diesel tanks.

The DieselMajor™ will take charge of your onsite diesel refueling, with a 10m retractable reel and high flow pump making your refueling task a breeze.

KEY FEATURES

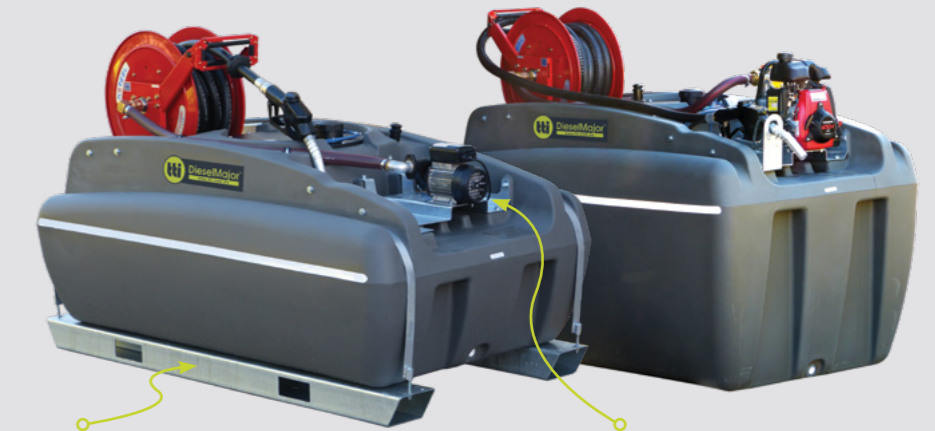
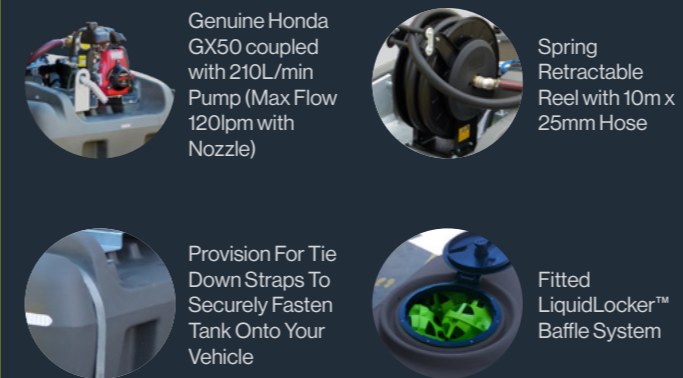

Note: Steel Frame as optional upgrade

12v Pump Options Available

210 L/min Pump, 10m Reel		
\$6,005*	\$6,295*	\$6,515*
600 Litres	800 Litres	1,000 Litres

SKU: DUCD0600LHB210

SKU: DUCD0800LHB210

SKU: DUCD1000LHB210



DieselCaptain™

Portable Diesel Tanks



Experience Hassle-Free Refueling

The Internationally Certified DieselCaptain™ is your ultimate and reliable refueling partner!

This range of poly diesel fuel tanks are equipped with world-class pumps, hoses and auto shut off nozzles, so you can be assured your diesel refueling is done quickly and efficiently.



25-YEAR TANK WARRANTY



INCORPORATED LIFTING HANDLES

DIESELCAPTAIN™

Portable Diesel Tanks

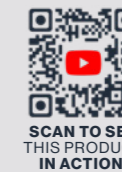

SCAN TO SEE THIS PRODUCT IN ACTION!



KEY FEATURES

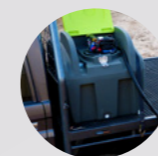

Heavy-duty Roto-molded Tank with Integrated Lifting Handles



Protected Tank Breather System & Anti-static Earth Strap



Fitted with High-flow Piusi or Transfer40 12v Diesel Pumps with 4m Battery Cables



3/4" or 1" Auto Shut Off Nozzle



6m (Piusi) or 4m (Transfer40) Anti-kink Delivery Hose



Double-hinged Lock-able Pump Cover Provides Pump Protection

DID YOU KNOW?



All DieselCaptain™ tanks are moulded with our unique aluminium lid mounting ring for incredible strength!

This unique multi-seal system keeps the moisture out and your diesel in!

DIESEL CAPTAIN™

Portable Diesel Tanks

Fitted with: ✓ 40L/min Transfer40 or 50L/min Piusi Pumps ✓ Auto Shut-Off Nozzle ✓ 4m Electrical Leads with Alligator Clips ✓ Delivery Hose



100 Litres

800 x 680 x 465mm (LWH) (Standard)

40L/min 12v Transfer40 Pump SKU: DUL0100LD040V1	50L/min 12v Piusi Pump SKU: DUL0100LF045V1
\$1,350*	\$1,680*

★ Steel Mounting Frame **\$615*** SKU: ASF000100



200 Litres

1150 x 820 x 565mm (LWH) (Low-Profile)

40L/min 12v Transfer40 Pump SKU: DUL0200LD040V1	50L/min 12v Piusi Pump SKU: DUL0200LF045V1
\$1,490*	\$1,840*

★ Steel Mounting Frame **\$615*** SKU: ASF000200



200 Litres

800 x 680 x 710mm (LWH) (Space Saver)

40L/min 12v Transfer40 Pump SKU: DUL0200ALD040V1	50L/min 12v Piusi Pump SKU: DUL0200ALF045V1
\$1,490*	\$1,840*

★ Steel Mounting Frame **\$615*** SKU: ASF000100



300 Litres

1270 x 600 x 790mm (LWH) (Slim)

40L/min 12v Transfer40 Pump SKU: DUL0300ALD040V1	50L/min 12v Piusi Pump SKU: DUL0300ALF045V1
\$1,780*	\$2,150*

★ Steel Mounting Frame **\$800*** SKU: ASF000400



400 Litres

1270 x 600 x 990mm (LWH) (Slim)

40L/min 12v Transfer40 Pump SKU: DUL0400ALD040V1	50L/min 12v Piusi Pump SKU: DUL0400ALF045V1
\$1,890*	\$2,270*

★ Steel Mounting Frame **\$800*** SKU: ASF000400



400 Litres

1150 x 820 x 780mm (LWH) (Standard)

40L/min 12v Transfer40 Pump SKU: DUL0400LD040V1	50L/min 12v Piusi Pump SKU: DUL0400LF045V1
\$1,890*	\$2,270*

★ Steel Mounting Frame **\$615*** SKU: ASF000200

DIESEL CAPTAIN™

Portable Diesel Tanks

Fitted with: ✓ 50L/min Piusi or 60L/min Fluid Pumps ✓ Auto Shut-Off Nozzle ✓ 4m Electrical Leads with Alligator Clips ✓ Delivery Hose

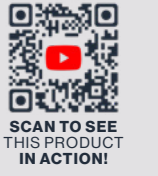

440 Litres

1700 x 880 x 620mm (LWH) (Standard)

40L/min 12v Transfer40 Pump SKU: DUL0440LD040V1	50L/min 12v Piusi Pump SKU: DUL0440LF045V1
\$2,110*	\$2,370*

★ Steel Mounting Frame **\$820*** SKU: ASF000440



600 Litres

1700 x 880 x 740mm (Standard)

50L/min 12v Piusi Pump SKU: DUL0600LF045V1	60 L/min 12v Fluid Pump SKU: DUL0600LF060V1
\$2,480*	\$2,800*

★ Steel Mounting Frame **\$820*** SKU: ASF000440



Inc LiquidLocker Baffles



800 Litres

1700 x 1000 x 860mm (LWH) (Standard)

60 L/min 12v Pump SKU: DUL0800LF060V1	80 L/min 12v Pump SKU: DUL0800LT080V1
\$3,420*	\$3,680*

★ Steel Mounting Frame **\$820*** SKU: ASF000440



Inc LiquidLocker Baffles



1,000 Litres

1700 x 1000 x 1025mm (LWH) (Standard)

60 L/min 12v Pump SKU: DUL1000LF060V1	80 L/min 12v Pump SKU: DUL1000LT080V1
\$3,650*	\$3,900*

★ Steel Mounting Frame **\$820*** SKU: ASF000440



Inc LiquidLocker Baffles



1,200 Litres

1700 x 1000 x 1190mm (LWH) (Standard)

60 L/min 12v Pump SKU: DUL1200LF060V1	80 L/min 12v Pump SKU: DUL1200LT080V1
\$3,890*	\$4,150*

★ Steel Mounting Frame **\$820*** SKU: ASF000440

UPGRADE OPTIONS



\$ SEE TABLES

Steel Frames

Forkliftable Steel Frames



\$393*

Flow Meter

5-Digit Flow Meters

SKU: ADFPE25D5

DieselCadet™

Diesel Transfer Refueling Tanks

Free-Standing Diesel Tanks

Tank Sizes:
50 - 10,000 Litres



Free-Standing with 25-Year Warranty

The DieselCadet™ poly diesel tanks are widely regarded for their versatility when transporting larger volumes of diesel. These free-standing diesel cartage tanks can be tray-mounted and kitted out with pumps and hose reels to suit different applications.

Note: Supplied with Pins for Easy Mounting & Securing (Above 500L)



KEY FEATURES

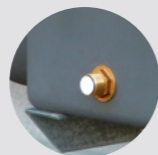

3/4" Drain Bung and Optional Brass Outlet



Heavy-duty, UV Stabilized Tank with 15-Year Warranty



4 x Mounting Pins Supplied for Easy & Secure Mounting



A Large Removable Plate Lid Allows Access to the Tank if Required

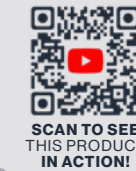

SCAN TO SEE THIS PRODUCT IN ACTION!



50 Litres

800 x 430 x 390mm (LWH)
SKU: DTC00050L

\$426*

100 Litres

900 x 450 x 475 mm (LWH)
SKU: DTC00100L

\$640*

ø150mm Lid & Seal Assy;
3/4" Drain Bung; Optional Outlet



220 Litres

925 x 710 x 510mm (LWH)
SKU: DTC00220L

\$750*

ø250 Lid & Seal Assembly;
3/4" Drain Bung; Optional Outlet

★ Steel Skid-Frame **\$675*** SKU: ASFD00220

★ Top-Mount Steel Pump Plate **\$295***



400 Litres

1620 x 710 x 510mm (LWH)
SKU: DTC00400L

\$1,200*

ø250 Lid & Seal Assembly;
3/4" Drain Bung; Optional Outlet

★ Steel Skid-Frame **\$800*** SKU: ASFD00400A

★ Top-Mount Steel Pump Plate **\$295***



500 Litres

1250 x 1070 x 580mm (LWH)
SKU: DTC00500L

\$1,365*

Mounting Pins Provided; ø250 Lid & Seal Assembly;
3/4" Drain Bung; Optional Outlet



600 Litres

1250 x 1070 x 740mm (LWH)
SKU: DTC00600L

\$1,610*

Mounting Pins Provided; ø455 Lid & Seal Assembly;
3/4" Drain Bung; Optional Outlet

★ LiquidLocker™ 16pcs **\$208***



800 Litres

1430 x 1220 x 670mm (LWH)
SKU: DTC00800L

\$1,985*

Mounting Pins Provided; ø455 Lid & Seal Assembly;
3/4" Drain Bung; Optional Outlet

★ LiquidLocker™ 17pcs **\$221***

DIESELCADET™

Free Standing Diesel Tanks



SCAN TO SEE THIS PRODUCT IN ACTION!



1,000 Litres

1430 x 1220 x 835mm (LWH)
SKU: DTC01000L

\$2,185*

Mounting Pins Provided; ø455 Lid & Seal Assembly;
¾" Drain Bung; Optional Outlet

★ LiquidLocker™ 24pcs **\$312***



1,200 Litres

1720 x 1230 x 840mm (LWH)
SKU: DTC01200L

\$2,310*

Mounting Pins Provided; ø455 Lid & Seal Assembly;
¾" Drain Bung; Optional Outlet

★ LiquidLocker™ 29pcs **\$377***



1,500 Litres

1720 x 1230 x 1000mm (LWH)
SKU: DTC01500L

\$2,880*

Mounting Pins Provided; ø455 Lid & Seal Assembly;
¾" Drain Bung; Optional Outlet

★ LiquidLocker™ 40pcs **\$520***



2,000 Litres

2150 x 1410 x 870mm (LWH)
SKU: DTC02000L

\$3,785*

Mounting Pins Provided; ø455 Lid & Seal Assembly;
¾" Drain Bung; Optional Outlet

★ LiquidLocker™ 55pcs **\$715***

★ Steel Mounting Frame **\$2,700*** SKU: ASFC02000



2,400 Litres

2150 x 1410 x 1140mm (LWH)
SKU: DTC02400L

\$4,310*

Mounting Pins Provided; ø455 Lid & Seal Assembly;
¾" Drain Bung; Optional Outlet

★ LiquidLocker™ 66pcs **\$858***

★ Steel Mounting Frame **\$2,700*** SKU: ASFC02000



3,000 Litres

2430 x 1540 x 1200mm (LWH)
SKU: DTC03000L

\$5,915*

Mounting Pins Provided; ø455 Lid & Seal Assembly;
¾" Drain Bung; Optional Outlet

★ LiquidLocker™ 85pcs **\$1,105***

★ Steel Mounting Frame **\$4,205*** SKU: ASFC03000

DIESELCADET™

Free Standing Diesel Tanks

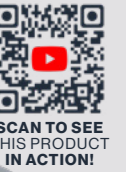

SCAN TO SEE THIS PRODUCT IN ACTION!



4,000 Litres

2430 x 1540 x 1450mm (LWH)
SKU: DTC04000L

\$6,805*

Mounting Pins Provided; ø455 Lid & Seal Assembly;
¾" Drain Bung; Optional Outlet

★ LiquidLocker™ 110pcs **\$1,430***

★ Steel Mounting Frame **\$4,205*** SKU: ASFC03000



5,000 Litres

2760 x 2000 x 1400mm (LWH)
SKU: DTC05000L

\$8,020*

Mounting Pins Provided; ø455 Lid & Seal Assembly;
¾" Drain Bung; Optional Outlet

★ LiquidLocker™ 138pcs **\$1,794***

★ Steel Mounting Frame **\$5,525*** SKU: ASFC05000



6,000 Litres

2760 x 2000 x 1540mm (LWH)
SKU: DTC06000L

\$10,220*

Mounting Pins Provided; ø455 Lid & Seal Assembly;
¾" Drain Bung; Optional Outlet

★ LiquidLocker™ 165pcs **\$2,145***

★ Steel Mounting Frame **\$5,525*** SKU: ASFC05000



7,000 Litres

3390 x 2250 x 1390mm (LWH)
SKU: DTC07000L

\$10,860*

Mounting Pins Provided; ø455 Lid & Seal Assembly;
¾" Drain Bung; Optional Outlet

★ LiquidLocker™ 190pcs **\$2,470***

★ Steel Mounting Frame **\$6,940*** SKU: ASFC07000



NEW!

8,000 Litres

3600 x 2100 x 1540mm (LWH)
SKU: DTC08000AL

\$13,510*

Mounting Pins Provided; ø455 Lid & Seal Assembly;
¾" Drain Bung; Optional Outlet

★ LiquidLocker™ 240pcs **\$3,120***

★ Steel Mounting Frame **\$6,940*** SKU: ASFC08000



10,000 Litres

3480 x 2250 x 1940mm (LWH)
SKU: DTC10000L

\$15,870*

Mounting Pins Provided; ø455 Lid & Seal Assembly;
¾" Drain Bung; Optional Outlet

★ LiquidLocker™ 295pcs **\$3,835***

★ Steel Mounting Frame **\$6,940*** SKU: ASFC07000

DieselCadet™

Free-Standing Diesel Tanks

with Pump & Optional Skid

Tank Sizes:
1,000 - 6,000 Litres



Comes with 25-Year Warranty

The DieselCadet™ with pump is a complete refueling solution, ready to be mounted onto a trailer or left stationary on the ground. Backed with a 15 Year Tank Warranty.



KEY FEATURES



Reliable 60L/min 12v Fluid Italian Pump with 4m Battery Cables

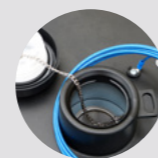

Large Removable Plate Lid with Pad-Lockable Filler Cap



6 Meters 1" Delivery Hose & Auto Shut-off Nozzle



4 x Mounting Pins Supplied for Easy and Secure Mounting



Pictured with Optional Frame & Reel

UPGRADE OPTIONS



\$464*

Filter

Cartridge Filter
(for 60L/min Pump Only)
SKU: ADC30M25DUC-F



\$393*

Flow Meter

5-Digit Flow Meters
SKU: ADFPE25D5



\$2,215*

10m Retractable Reel

10m of 25mm Hose & 1" Nozzle
SKU: ADHR010M25



See Table

Steel Frames

Steel-Mounting Frames
SEE TABLE FOR PRICING



POA

LiquidLocker™

LiquidLocker™ Ball Baffles
CONTACT US FOR PRICING



\$1,830*

GX160 Engine

GX160 Honda & 490L/min Pump
UPGRADE PRICE FROM 60LPM 12V PUMP

DieselCadet™ with 60L/min 12v Pump			
CODE	CAPACITY (LITRES)	RRP*(\$)	STEEL FRAME
DUC1000LF060V1	1,000 Litres	\$3,480*	\$2,820*
DUC1200LF060V1	1,200 Litres	\$3,770*	\$2,990*
DUC1500LF060V1	1,500 Litres	\$4,220*	\$2,990*
DUC2000LF060V1	2,000 Litres	\$5,030*	\$2,700*
DUC2400LF060V1	2,400 Litres	\$5,635*	\$2,700*
DUC3000LF060V1	3,000 Litres	\$6,885*	\$4,205*
DUC4000LF060V1	4,000 Litres	\$8,410*	\$4,205*
DUC5000LF060V1	5,000 Litres	\$9,710*	\$5,525*
DUC6000LF060V1	6,000 Litres	\$12,065*	\$5,525*

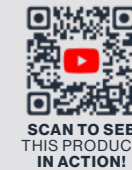

SCAN TO SEE THIS PRODUCT IN ACTION!



DIESEL REFUELING TRAILERS

DieselPatrol14™

Diesel Transfer Refueling Trailers

TTI's DieselPatrol14™ Refueling Trailer is a simple yet effective solution, at an affordable price.

Providing serious bang for your buck, the DieselPatrol14 provides safe and hassle-free refueling for your plant and equipment.

Featuring a robust galvanized chassis, heavy duty poly diesel tank, high flow pump mounted in a toolbox, the DieselPatrol14 will deliver effortless refueling of equipment.

KEY FEATURES



50L/min 12v Piusi Pump Mounted in Lockable Toolbox



Heavy-Duty Poly Tank with LiquidLocker™ Baffles



Galvanised Chassis with 50mm 2T-Rated Galvanised Axles & 14" Wheels



LED Combination Tail & Number Plate Lights



SCAN TO SEE THIS PRODUCT IN ACTION!

\$9,380*

1,000 Litres (UnBraked)

UnBraked with 50L/min 12v Piusi Pump; with Lights; Unbraked

SKU: DSRX1000LF045V1

\$11,860*

1,000 Litres (with Brake)

Braked / Registerable with 50L/min 12v Piusi Pump; with Lights; with Brakes

SKU: DSRQ1000LF045V1

UPGRADE OPTIONS



\$660*

Cartridge Filter

SKU: ADC30M25-F



\$2,215*

10m Retractable Hose Reel

SKU: ADHR10M25



We Are an Approved
VicRoads Trailer Registration Dealer!

DieselPatrol15™

Diesel Refueling Trailers

TTi's DieselPatrol15™ Refueling Trailers are the professionals choice for providing safe and hassle-free refueling for your plant and equipment.

The DieselPatrol15 features a robust galvanized chassis, heavy duty poly tanks, high flow pumps, and optional hose reels, for ultimately delivering effortless refueling of your equipment.

DIESELPATROL15™

Refueling Trailers



KEY FEATURES



Galvanised Chassis with 65mm 2T-Rated Galvanised Axles & 15" Landcruiser Wheels



Recessed LED Combination Tail Lights & License Plate Light

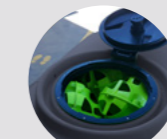

Fully-Drainable UV Stabilised Poly Tank with LiquidLocker™ Baffles



Diesel Cartridge Filter 30micron (Water Absorbing)



10m Retractable Reel with 10m of 25mm Hose & 1" Nozzle



4-Digit Mechanical Flow Meter

PUMP OPTIONS

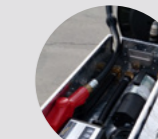

Fluid Italian 60L/min 12v Pump Mounted in Lockable Toolbox



GX160 Honda & 490L/min Pump with Pressure Relief

*GST included | Freight Rates Apply

Trans Tank® International | Product Catalogue 2025

DIESELPATROL15™

Single Axle Refueling Trailers

SINGLE AXLE

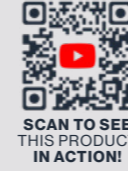

800 Litres

12v 60L/min Pump		Honda GX160 490L/min Pump	
\$13,175*	\$15,810*	\$16,125*	\$18,760*
UnBraked	Hydraulic Braked; Registerable	UnBraked	Hydraulic Braked; Registerable

1,000 Litres

12v 60L/min Pump		Honda GX160 490L/min Pump	
\$13,290*	\$16,180*	\$16,240*	\$19,130*
UnBraked	Hydraulic Braked; Registerable	UnBraked	Hydraulic Braked; Registerable



1,200 Litres

12v 60L/min Pump		Honda GX160 490L/min Pump	
\$14,340*	\$17,230*	\$17,290*	\$20,180*
UnBraked	Hydraulic Braked; Registerable	UnBraked	Hydraulic Braked; Registerable

1,500 Litres

12v 60L/min Pump		Honda GX160 490L/min Pump	
\$14,865*	\$17,700*	\$17,815*	\$20,650*
UnBraked	Hydraulic Braked; Registerable	UnBraked	Hydraulic Braked; Registerable

DIESELPATROL15™

Dual Axle Refueling Trailers

DUAL AXLE



1,500 Litres

12v 60L/min Pump		Honda GX160 490L/min Pump	
\$18,074*	\$23,585*	\$21,025*	\$26,535*
UnBraked	Electric Braked; Registerable	UnBraked	Electric Braked; Registerable

2,000 Litres

12v 60L/min Pump		Honda GX160 490L/min Pump	
\$19,240*	\$24,980*	\$22,190*	\$27,930*
UnBraked	Electric Braked; Registerable	UnBraked	Electric Braked; Registerable



2,400 Litres

12v 60L/min Pump		Honda GX160 490L/min Pump	
\$19,925*	\$25,680*	\$22,875*	\$28,630*
UnBraked	Electric Braked; Registerable	UnBraked	Electric Braked; Registerable

3,000 Litres

12v 60L/min Pump		Honda GX160 490L/min Pump	
\$22,855	\$28,205*	\$25,805*	\$31,155*
UnBraked	Electric Braked; Registerable	UnBraked	Electric Braked; Registerable

DIESEL ACCESSORIES

Auto Shut-Off Diesel Nozzles

Reliable Auto Shut-Off Nozzles in 2 Sizes

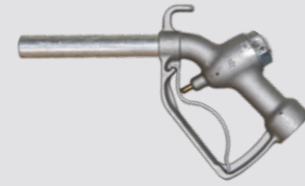

3/4" Manual Fuel Dispensing Nozzle

\$136*

BSP Connection; Aluminium Construction
SKU: AD6M20



3/4" Auto Shut-off Fuel Dispensing Nozzle

\$179*

Supplied Standard with all 50L/min Pump Kits
SKU: ADGA20



1" Auto Shut-off Fuel Dispensing Nozzle

\$268*

Supplied Standard with all 60L/min Pump Kits
SKU: ADGA25

Diesel Hose

- Choose from 6 & 10 metre hose lengths
- Choose from 3/4" and 1" hose diameter
- High quality diesel grade hose with crimped fittings
- Hose kinking prevented by anti-kink spring



SKU	DESCRIPTION	RRP*(\$)
ADZF6M20	Diesel hose 6 metres 20mm with crimped ends	\$191
ADZF6M25	Diesel hose 6 metres 25mm with crimped ends	\$303
ADZF10M25	Diesel hose 10 metres 25mm with crimped ends	\$365

Assembly: Lid & Filter

- Pad-lockable, non vented diesel filler lid with strainer & anti-loss chain
- Used in all TransDiesel units
- #50 mesh filter at fill point helps prevent contamination of your fuel



Diesel Lid Cap with Chain

\$98*

SKU: ADLC001CC

Lid & Filter Assembly

\$182*

SKU: ADLC001CCF

DIESEL ACCESSORIES

Fuel Level Gauge

Never guess your fuel level again!

- Fits neatly beside filler cap
- Easy to read fuel level gauge for DieselCaptain units

SKU	DESCRIPTION	RRP*(\$)
ADLM01MK	250mm Fuel Level Gauge	\$156
ADLM02MK	300mm Fuel Level Gauge	\$162
ADLM03MK	400mm Fuel Level Gauge	\$172
ADLM04MK	500mm Fuel Level Gauge	\$177
ADLM05MK	600mm Fuel Level Gauge	\$187



3/4" Brass Hose Swivel

\$81*

3/4" MBSP to 3/4" FBSP
SKU: CFSBB20M20F



1" Brass Hose Swivel

\$97*

1" MBSP to 1" FBSP
SKU: CFSPB25M25F



Diesel Cartridge Filter 70 L/min

\$181*

SKU: ADC30M25F



Diesel Cartridge Filter 150 L/min

\$392*

SKU: EFHD-15010-25



Honda GX160 Pump Kit

\$3,110*

GX160 Honda & 490L/min Pump
SKU: ADPX4900ZK



Diesel Hose Reel

\$2,215*

10m of 25mm Hose & 1" Nozzle
SKU: ADHR010M25



5-Digit Flow Meter (Digital)

\$393*

5-Digit Flow Meter (Digital)
SKU: ADFPE25D5



4-Digit Flow Meter (Mechanical)

\$406*

4-Digit Flow Meter
SKU: ADFMM25D4

DIESEL PUMPS

PUMP ONLY

12v Transfer40 Pump

- 12 volt 40L/min open flow rate
- Improved heavy duty switch
- Supplied with suction filter
- 3/4" BSP ports
- Self priming
- Reliable & compact
- Redesigned integrated bypass valve
- 4 metres of electrical cable with battery clips



Transfer40 40L/min Pump

\$358*

12v with Battery Cables
SKU: ADPX2040V1P

12v 45L/min Fluid Pump

- 12 volt rotary electric vane pump
- Integrated suction filter & bypass valve
- 4 metres of electrical cable with battery clips
- 3/4" Female threaded ports
- Self priming
- Reliable & compact
- Made in Italy



Fluid 45L/min Pump

\$610*

12v with Battery Cables
SKU: ADPF045V1P

12v 50L/min Piusi Pump

- 12 volt rotary electric vane pump
- 4 metres of electrical cable with battery clips
- 1" suction port
- 3/4" discharge port
- Self priming
- Reliable & compact
- Made in Italy



Piusi 50L/min Pump

\$610*

12v with Battery Cables
SKU: I-12578

12v 60L/min Fluid Pump

- 12 volt rotary electric vane pumps
- Integrated suction filter & bypass valve
- 4 metres of electrical cable with battery clips
- 1" BSP ports
- Self priming
- Reliable & compact
- Made in Italy



Fluid 60L/min Pump

\$940*

12v with Battery Cables
SKU: ADPF060V1P

24v 60L/min Fluid Pump

- 24 volt rotary electric vane pumps
- Integrated suction filter & bypass valve
- 1" BSP ports
- Self priming
- Reliable & compact
- Made in Italy
- 4 metres of electrical cable with battery clips



Fluid 60L/min Pump

\$985*

24v with Battery Cables
SKU: ADPF060V2P

240v 60L/min Fluid Pump

- 60 L/min 240 volt diesel pump kit
- Made in Italy
- 1" Female BSB Threaded Ports



Fluid 60L/min Pump

\$1,090*

240v with Plug
SKU: ADPF060V3P

Adam 12v 85L/min Pump

- 12v 85L/min Adam Pump
- Easy clean suction strainer
- On/off switch on pump
- 1 1/4" suction; 1" discharge (threaded ports)



Adam 85L/min Pump

\$1,250*

12v with Battery Cables
SKU: ADPT085V1P

DIESEL PUMPS

KITS

12v 40L/min Transfer40 Kit

- Improved heavy duty switch
- Supplied with suction filter
- 3/4" BSP ports
- Self priming
- Reliable & compact
- 4 metres delivery hose
- 2 metres of 25mm suction hose
- 4 metres of electrical cable with battery clips



Transfer40 40L/min Kit

\$610*

12v with Battery Cables
SKU: ADPX2040V1K

12v 50L/min Piusi Kit

- Automatic nozzle with swivel to prevent hose tangles
- Easy clean suction strainer
- 1" Suction; 3/4" Discharge Tails
- Bypass valve integrated on pump body
- 4 metres of power cable + battery clips
- 2 metres of 25mm suction hose
- 6 metre delivery hose
- Made in Italy



Piusi 50L/min Kit

\$960*

12v with Battery Cables
SKU: ADPF045V1K

12v 60L/min Fluid Kit

- Automatic nozzle with swivel to prevent hose tangles
- Easy clean suction strainer
- 1" BSP threaded connectors
- Bypass valve integrated on pump body
- 4 metres of power cable + battery clips
- 2 metres of 25mm suction hose
- 6 metre delivery hose
- Made in Italy



Fluid 60L/min Kit

\$1,280*

12v with Battery Cables
SKU: ADPF060V1K

24v 60L/min Fluid Kit

- 60L/min 24 volt diesel pump kit
- 4 metres of power cable + battery clips
- 2 metres of 25mm suction hose
- 6 metres of 25mm anti-static delivery hose with anti-kink spring + auto shut-off nozzle
- Made in Italy



Fluid 60L/min Kit

\$1,340*

24v with Battery Cables
SKU: ADPF060V2K

240v 60L/min Fluid Kit

- 60L/min 240 volt diesel pump kit
- 2 metres of 25mm suction hose
- Made in Italy
- 6 metres of 25mm anti-static delivery hose with anti-kink spring and auto shut-off nozzle



Fluid 60L/min Kit

\$1,705*

240 with Plug
SKU: ADPF060V3K

12v 85L/min Adam Pump Kit

- Automatic nozzle with swivel to prevent hose tangles
- Easy clean suction strainer
- On/off switch on pump
- 1 1/4" suction; 1" discharge (threaded ports)



Adam 85L/min Kit

\$2,090*

12v with Battery Cables
SKU: ADPT085V1K

BluEmission™

Diesel Exhaust Fluid (DEF)

- ◆ 35L/min flow rate
- ◆ Stainless steel lid and auto shut-off nozzle for controlled dispensing
- ◆ Stainless steel pump with internal bypass for durability and ease of use
- ◆ Stainless steel breather mounted behind lid
- ◆ 4m of electrical cable with battery clips
- ◆ EPDM gaskets and seals
- ◆ Tank manufactured from urea grade polyethylene - Diesel Exhaust Fluid (DEF) compatibility
- ◆ Filler cap Diesel Exhaust Fluid (DEF) compatible
- ◆ 4 metres of 19mm flexible delivery hose

AFFORDABLE BULK ADBLUE TRANSPORTABLE TANKS

- ✔ Enjoy the Poly Advantage of No Rust!
- ✔ Available Tank Sizes: 1,000L to 30,000L
- ✔ Extra UV Stabilisation - Protects the Tank from ever Deteriorating in Direct Sunlight
- ✔ Tanks are Designed to Carry the Extra Weight of AdBlue
- ✔ 25-Year Tank Warranty

Call us Today to Discuss
Your Specific Requirements



\$2,620*

100 Litres

100 Litre with 35L/min Pump and Auto Nozzle
800 x 680 x 465mm (LWH)

SKU: DAL0100LT035AV1



\$2,895*

200 Litres

200 Litre with 35L/min Pump and Auto Nozzle
800 x 680 x 710mm (LWH)

SKU: DAL0200ALT035AV1

- ✔ Diesel Exhaust Fluid (DEF)
- ✔ Dispenser with 35L/min flow rate
- ✔ Fully enclosed lockable pump compartment for security and protection



FIRE
FIGHTING
EQUIPMENT

StandBy10™

Hand-Held / Tractor-Mount
Fire Fighters

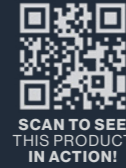

SCAN TO SEE
THIS PRODUCT
IN ACTION!



- ◆ Fast & consistent flow from double-action hand pump
- ◆ Adjustable nozzle for effective performance in varying conditions;
- ◆ Supplied with spring steel mounting brackets;
- ◆ UV stabilised roto-molded poly tank

\$466*

10 Litres

**10 Litre Tractor Mount Fire Fighter
with Spring Steel Mounting Brackets**

SKU: PFT0010L



BackUp16™

Knapsack Fire Fighter



SCAN TO SEE
THIS PRODUCT
IN ACTION!

- ◆ Fast & consistent flow from double-action hand pump
- ◆ Ideal for spark/ember suppression, managing spot fires & burning off
- ◆ Comfortable to wear, easy to carry, and easy to use
- ◆ Adjustable nozzle for effective performance in varying conditions
- ◆ Unique grease-ring pump lubrication



\$399*

16 Litres

16 Litre Knapsack Fire Fighter
SKU: PFK0016L



\$205*

Frame

Vehicle Carry Frame to Suit Backup16™
SKU: ASFF00016



ARE YOU READY FOR FIRE SEASON?

In the heat of the moment, you can always rely on TTI's Fire Fighting Equipment!

FIRE FIGHTING HOSE REELS

High-Quality, Multi Purpose Manual & Spring Rewind Hose Reels

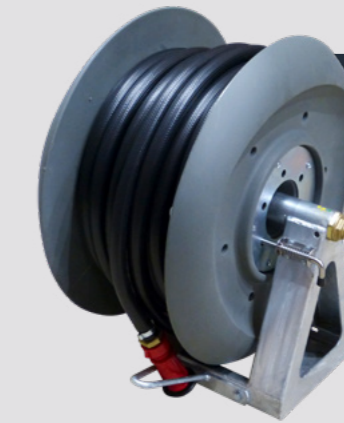

NEW & IMPROVED
POLY REEL

\$1,005*

36m Hose Reel (Poly)

Manual rewind poly hose reel with 36m of 19mm
hose & adjustable nozzle

SKU: AFHW10B036M19



\$2,095*

**20m Spring Rewind
Hose Reel (Steel)**

Spring rewind steel reel with
20m x 25mm hose & adjustable nozzle

SKU: ATHW020SR

FireCombat™

Portable Fire Fighter



- ◆ Honda GX160 Motor with 500L/min Davey Single Impeller 1½" Pump
- ◆ Pressure relief valve and bypass to protect pump;
- ◆ Camlock fittings and 6m quick fill kit for filling from external water source;
- ◆ 18m x 19mm Fire hose with adjustable nozzle

\$4,200*

400 Litres

Honda GX160 with Davey Pump
1620 x 710 x 810mm (LWH)
SKU: SFO400LZ

FireGuard™

Portable Fire Fighters

- ◆ Handy size fire fighter for rapid response to fire emergencies;
- ◆ GX50 Honda motor, 210L/min FF pump for fast & reliable flow;
- ◆ 18 metres of fire hose with twist action adjustable FF nozzle
- ◆ UV stabilised tank with 25-year warranty



\$2,785*

220 Litres

Honda GX50 with 210L/min Pump
925 x 710 x 810mm (LWH)
SKU: SFO220LZ



Steel Skid-Frame SKU: ASFD00220

\$675*

\$3,245*

400 Litres

Honda GX50 with 210L/min Pump
1620 x 710 x 810mm (LWH)
SKU: SFO400LZS



★ Steel Skid-Frame SKU: ASFD00400A

\$800*

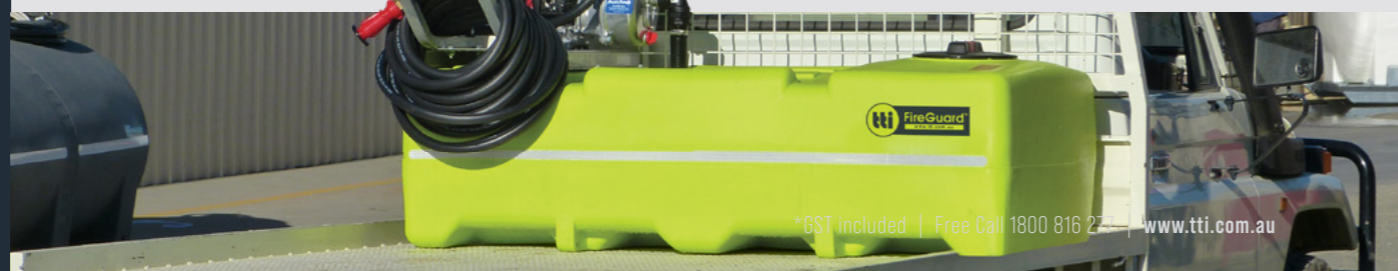

*GST Included | Free Call 1800 816 222 | www.tti.com.au

FireBoss™

UTV Fire Fighting Unit

Sitting neat and sitting low, the TTI FireBoss™ UTV fire fighting unit is always right behind you, when performing your fire duties.

From fire fighting, tree watering, washdown, and more, the FireBoss™ slip-on UTV firefighter lives up to its name.

KEY FEATURES

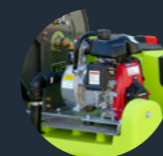

Honda GX50 Motor with 210L/min Pump for Fast and Reliable Flow

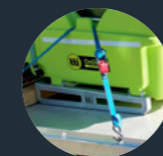

Fully-Drainable Tank Tie-Down Provisions & Integrated Lifting Handles



18m Hose Reel with Adjustable Nozzle



Galvanised Forkable Steel Frame



(Standard)

\$4,980*

300 Litres

Honda GX50 with 210L/min Pump
1000 x 1250 x 600mm (LWH)

SKU: PFD0300LZS



(Compact)

\$4,980*

300 Litres

Honda GX50 with 210L/min Pump
870 x 1100 x 850mm (LWH)

SKU: PFD0300LZS



FireDefence™

Slip-On Fire Fighting Unit



A compact combo that always delivers punch, the FireDefence™ is in a class of its own.

The unique mounting of the pump, motor and reel ensures the centre of gravity is low and safe, making it the perfect choice for property owners.

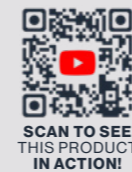

SCAN TO SEE THIS PRODUCT IN ACTION!

KEY FEATURES



Honda GX160 Motor with 500L/Min Davey Single Impeller 1 1/2" Pump

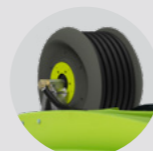

36m Hose Reel with Adjustable Nozzle

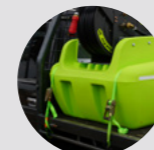

UV Stabilised Poly Tank with Tie-Down Provisions & Integrated Lifting Handles



LiquidLocker™ Baffling System Fitted



6m Suction Fill Kit for Filling from External Water Source



Low-Profile Design for Safety and Stability



FIREFENCE™

Slip-On Fire Fighting Unit

Heavy-Duty Fire Fighters

Ideal for Tray or Trailer Mounting



\$5,955*

600 Litres

1700 x 1000 x 990mm (LWH)
SKU: SFD0600LZ

\$6,105*

800 Litres

1700 x 1000 x 1155mm (LWH)
SKU: SFD0800LZ

\$6,340*

1000 Litres

1700 x 1000 x 1320mm (LWH)
SKU: SFD1000LZ

UPGRADE OPTIONS



\$820*

Frame Upgrade

Forkliftable Steel Frame
SKU: ASF00440



\$451*

Pump Upgrade

Davey Twin Impeller Pump
SKU: ADD "T" TO END OF SKU



\$806*

Reel Upgrade

20m Spring Rewind Reel
SKU: ADD "S" TO END OF SKU

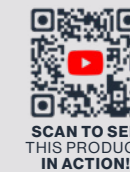

SCAN TO SEE THIS PRODUCT IN ACTION!

FireAttack™

Skid-Mounted Fire Fighting Unit

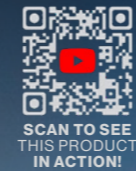

KEY FEATURES

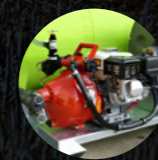

Honda GX200 Engine with 400l/Min Davey Twin Impeller 1½" Pump



36m x ¾" Heavy-Duty Hose Reel with Adjustable Twist Type Nozzle



Heavy-Duty Galvanised Skid Frame with Forklift Pockets



UV Stabilised Fully-Drainable Tank with Liquidlocker™ Baffle System



6m Suction Fill Kit for Filling from External Water Source



Pressure Relief Bypass Ensures Pump Remains Cool when In Operation

Always action ready, the FireAttack™ lineup of slip on firefighting units are the choice of serious property owners.

During the heat of the moment, when every drop counts, the fully draining tank and Davey Twin Impeller pump will deliver under pressure!

FIREATTACK™

Skid-Mounted Fire Fighting Unit



\$7,060* **400 Litres**

1480 x 1220 x 1000mm (LWH)
SKU: PFUS0400LZF



\$7,165* **500 Litres**

1740 x 1250 x 760mm (LWH)
SKU: PFU0500LZF



\$7,410* **600 Litres**

1740 x 1250 x 920mm (LWH)
SKU: PFU0600LZF



\$7,580* **800 Litres**

1900 x 1440 x 810mm (LWH)
SKU: PFU0800LZF



\$7,980* **1,000 Litres**

1900 x 1440 x 980mm (LWH)
SKU: PFU1000LZF



\$8,435* **1,500 Litres**

1900 x 1700 x 1250mm (LWH)
SKU: PFU1500LZF

AquaPath™

Skid-Mounted Water Carts

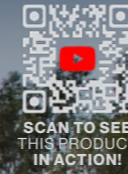

SCAN TO SEE THIS PRODUCT IN ACTION!



KEY FEATURES

TTi's tough and robust AquaPath™ is perfect for civil works, dust suppression, tree watering and fire fighting.

This AquaPath™ slip-on water cart is simple, effective & reliable, and will be sure to get any water transport job done with ease! Our range of accessories and options ensures we can provide you with the perfect AquaPath™ water cart for your needs!

Tested and ready to be mounted on any tipper, flat tray or trailer!



Honda GX200 6.5hp Engine with 400L/Min 1½" Davey Twin Impeller Pump



36m Heavy-Duty Hose Reel with Adjustable Nozzle



Dual Deflector Sprayer Kit with Wireless Remote Control



Heavy-Duty Poly Tank with Liquidlocker™ Baffle System



Galvanised Steel Skid Frame with Forklift Pockets



6m Suction Fill Kit for Filling from External Water Source



AQUAPATH™

Skid-Mounted Water Carts

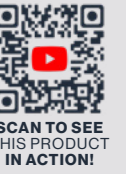

SCAN TO SEE THIS PRODUCT IN ACTION!



Note: Pictured with optional Hydrant Filler Kit

Now Fitted Standard with:
Dual Deflector Sprayer Kit with Wireless Remote Control!

UPGRADE OPTIONS



\$1,640*

Honda Elec Start Engine

Honda Electric Start Engine with Battery Pack



\$3,990*

Yanmar Diesel Engine 4.8hp

Electric Start with Battery Pack and Davey Pump



\$1,980*

Hydrant Fill Lid

3" Hydrant Fill Lid



\$806*

Spring Rewind Reel

18m x 25mm hose and adjustable F/F nozzle



SCAN TO SEE THIS PRODUCT IN ACTION!



\$14,440*

2,000 Litres

2910 x 1410 x 958mm (LWH)



\$14,885*

2,400 Litres

2910 x 1410 x 1228mm (LWH)



\$17,895*

3,000 Litres

3020 x 1540 x 1340mm (LWH)



\$19,470*

4,000 Litres

3020 x 1540 x 1590mm (LWH)



\$22,305*

5,000 Litres

3500 x 2000 x 1569mm (LWH)



\$23,805*

6,000 Litres

3500 x 2000 x 1709mm (LWH)

AQUAPATH™ TESTIMONIALS



SCAN TO SEE THIS PRODUCT IN ACTION!



“ Highly recommend one of these TTi AquaPath™ units to anyone in the civil industry.”

Peter Atkinson

Bulldog Earthmoving
Civil Contractor



“ Very easy to take off the truck for something else if we're not using the tank. We've got six AquaPath™ units across the company. They're very versatile, easy to fill-up and make it a lot easier on site.

Michael Hanly

ACE Contractors Group Civil and Landscaping



“ Highly recommend TTi, I couldnt recommend them any more, they always have the after sales service, and will hand deliver the unit! You cant ask for any better service!

Neil and Gareth

Regal Innovations Civil and Landscaping

FirePatrol14™

Water Cartage Trailer



Simple, safe and effective sums up the FirePatrol14™ water cart trailer. Clearly a market leader.

A great property owners choice for a range of applications such as firefighting, water transfer, washdown and wherever else you need water.



KEY FEATURES

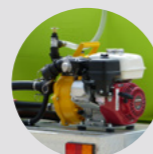

GX160 Honda Motor with 1½" Single Impeller Davey 500L/Min Pump



36m Heavy-Duty Hose Reel with Adjustable Nozzle



Galvanised Chassis with 50mm 2T-Rated Galvanised Axles & 14" Wheels



Heavy-Duty Poly Tank with LiquidLocker™ Baffles



6m Suction Fill Kit with Bracket for Filling from External Water Source

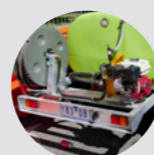

Led Combination Tail & Number Plate Lights

Multi-Purpose Water Cart Trailer

for Fire Fighting, Dust Suppression and Tree Watering



\$10,460*

1,000 Litres

UnBraked

SKU: SRFQ1000LZ

\$12,230*

1,000 Litres

Braked / Registerable

SKU: SRFQ1000LZ

Now fitted with **LiquidLocker™** Baffle System!



UPGRADE OPTIONS



\$1,640*

Honda Electric Start Engine

Honda Electric Start Engine with Battery Pack



\$2,935*

Deflector Sprayer Kit with Actuator

Single Deflector with Actuator Valve & Wireless Remote Control



\$915*

Deflector Spray Kit Manual Control

1.5 inch Single Deflector, Ball Valve & Pipework



We Are an Approved

VicRoads Trailer Registration Dealer!

FirePatrol15™

Australia's No: 1 Water Cartage Trailer

Robust, safe and engineer approved, the FirePatrol15™ line up of water cartage trailers are still being voted 'Best & Fairest' on and off the road!

High performing and versatile, they make putting 'water to work' a pleasure!

FIREPATROL15™

Australia's No: 1 Water Cartage Trailer



SINGLE AXLE



DUAL AXLE

KEY FEATURES



Reliable Honda GX200 Engine & 400L/Min Davey Twin Impeller Pump



36m Heavy-Duty Hose Reel with Adjustable Nozzle



Galvanised Chassis with 65mm 2T-Rated Galvanised Axles & 15" Landcruiser Wheels



Recessed Led Combination Taillights & License Plate Light



Fully-Drainable UV Stabilised Poly Tank With Liquidlocker™ Baffles

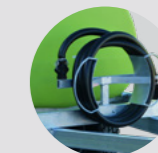

6m Suction Fill Kit with Bracket for Filling from External Water Source

UPGRADE OPTIONS



\$3,990*

Yanmar Diesel Engine 4.8hp

Electric Start with Battery Pack and Davey Pump



\$1,640*

Honda Elec Start Engine

Honda Electric Start Engine with Battery Pack



\$915*

Single Deflector

1.5" Deflector, Ball Valve & Pipework



\$3,883*

Dual Deflectors

1.5" Deflectors, Single actuator Valve with Remote Control & Pipework



\$1,090*

Spring Rewind Reel

18m x 25mm Hose and Adjustable F/F Nozzle



\$1,980*

Hydrant Fill Lid

3" Hydrant Fill System



SCAN TO SEE THIS PRODUCT IN ACTION!

FIREPATROL15™

Australia's No. 1 Water Cartage Trailer

SINGLE AXLE

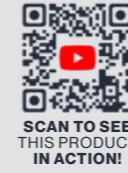

800 Litres

\$12,700* **\$14,595***

Unbraked **Braked Registerable**
(Hydraulic Brakes)
SKU: PRFX0800LZ SKU: PRFQ0800LZ



1,000 Litres

\$13,150* **\$15,215***

Unbraked **Braked Registerable**
(Hydraulic Brakes)
SKU: PRFX1000LZ SKU: PRFQ1000LZ



1,200 Litres

\$14,410* **\$16,490***

Unbraked **Braked Registerable**
(Hydraulic Brakes)
SKU: PRFX1200LZ SKU: PRFQ1200LZ

FIREPATROL15™

Australia's No. 1 Water Cartage Trailer

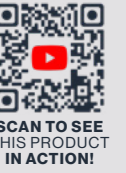

1,500 Litres

\$17,200* **\$22,040***

Unbraked **Braked Registerable**
(Electric Brakes)
SKU: PRFXD1500LZ SKU: PRFQD1500LZ



2,000 Litres

\$19,700* **\$23,670***

Unbraked **Braked Registerable**
(Electric Brakes)
SKU: PRFXD2000LZ SKU: PRFQD2000LZ



2,400 Litres

\$20,250* **\$24,095***

Unbraked **Braked Registerable**
(Electric Brakes)
SKU: PRFXD2400LZ SKU: PRFQD2400LZ



3,000 Litres

\$22,280* **\$27,380***

Unbraked **Braked Registerable**
(Electric Brakes)
SKU: PRFXD3000LZ SKU: PRFQD3000LZ



PantherPatrol™

State-of-the-Art
Water Cartage Trailer

Clearly a market leading water cart trailer.

The state of the art TTI PantherPatrol™ Trailer Mounted Water Cart includes an inbuilt handwash tank and toolbox, and can be used for firefighting, washdown and tree watering.

KEY FEATURES



Genuine GX200
Honda Motor
Twin Impeller
Davey Fire
Fighting Pump



36m of 19mm
Hose Fire
Fighting Hose
Reel with
Adjustable
Nozzle



15" wheels with
Landcruiser
Hub Pattern with
Galvanised Steel
Frame



LiquidLocker™
Baffling System



SCAN TO SEE
THIS PRODUCT
IN ACTION!

1,100 Litres

\$13,800*

Unbraked
Honda GX200 with Twin Impeller
Davey Pump
SKU: PRFPX1100LZ

\$16,825*

Braked / Registerable
Honda GX200 with Twin Impeller
Davey Pump
SKU: PRFPQ1100LZ



*GST included | Free Call 1800 916 277 | www.tti.com.au



CIVIL EQUIPMENT

PolymerPro™

Polymer Application Trailer



TTi's market-leading solution for transporting and applying polymer – The PolymerPro™.

TTi's latest innovation is designed specifically for industries like civil construction, commercial landscaping, and mining. The Polymer Pro Trailer makes applying polymer chemicals easier and more efficient than ever before.



SCAN TO SEE THIS PRODUCT IN ACTION!



KEY FEATURES

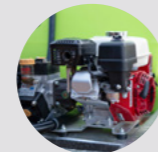

Genuine Honda GX200 Petrol Engine coupled with a Polmer-Spec 75L/Min Bertolini Pump



Twin Agitator System & Pressure Bypass



4-way pressure regulator and gauge for accurate & controlled spraying



Complete with 36m x 19mm Hose and brass nozzle designed for polmer application



100L freshwater tank plumbed to the main tank with a valve for flushing



Venturi Quick Fill Kit - Easy tank filling from external water source or sucking polmer from IBC/ drums into the tank

Available in 1,000 & 2,000 Litres



SCAN TO SEE THIS PRODUCT IN ACTION!



UPGRADE OPTIONS



Honda Electric Start Engine
Honda Electric Start Engine with Battery Pack



Dual Deflector Sprayer Kit with Actuator

1.5" Dual Deflector with Actuator Valve & Wireless Remote Control



Deflector Spray Kit Manual Control

1.5 inch Single Deflector, Ball Valve & Pipework

4X2 / 6X4 PACKAGES



Water Trucks

At TTI, we have been manufacturing and supplying reliable water truck solutions for Civil Contractors, Landscapers, Councils and Hire Companies across the country for over 20 years. TTI's water trucks simply work when you need them to.

WATER TRUCKS

FEATURES



HEAVY-DUTY POLY TANK

Tough, rotomolded poly tank with a 20-Year Warranty, reflective decals & rear/side site tubes

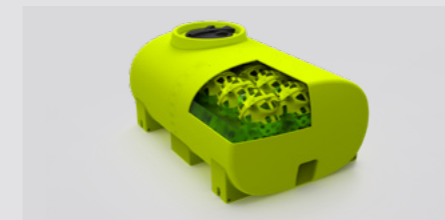

LIQUIDLOCKER™ Baffle System

100% Elimination of liquid surge for safe water transport



ENGINEER APPROVED CHASSIS FRAME

Galvanised, engineer-approved subframe, fitted to truck chassis. VASS Certificate supplied.



EASY-TO-USE IN-CAB CONTROLLER

Ergonomic In-cab control panel mounted in the cabin



HYDRAULIC PUMP SYSTEM

Variable Speed Hydraulic system complete with Hydra Pak, PTO to Truck, Piston Pump, Hydraulic valving and controls



1600 L/MIN CAST IRON PUMP

1600L/min, Self Priming, Australian Made Cast Iron Pump with pressure relief



3" REAR SPRAY HEADS

Central 3" & two 1.5" left and right magnum spray heads with individual on/off. Adjustable roll groove mounting



PRESSURISED AND/OR GRAVITY DRIBBLE BAR

Featuring 3" Pressurised and/or Gravity Dribble Bar's



3" WATER CANNON (ELECTRIC)

Electric nozzle for spray pattern control; In-cab joystick; Australian Made



BATTER SPRAY HEADS

2x Batter spray heads mounted on each side of the truck between the tank and the cab



FRONT SPRAY HEADS

2 x Front spray frog nozzles mounted on front of the truck - individual on/off



WORK LIGHTS

Engineered-for-purpose water cart vehicles. Built to your specifications to suit any mining, civil, or commercial environment.

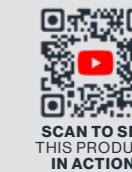

4X2 TRUCK PACKAGES

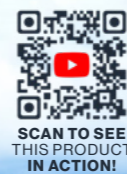

8,000L

8,000L (HINO 4x2)



8,000L (ISUZU 4x2)



8,000L (HINO 4x2)



6X4 TRUCK PACKAGES



13,000L & 15,000L

13,000L (UD 6x4)



15,000L (HINO 6x4)



15,000L (ISUZU 6x4)



WATER TRUCK CHASSIS-MOUNT MODULES

AquaModule™

TTi offers remote supply modules, which is the perfect solution if you have the desire to do your own 'fit-off' of a complete water cart module.

Design, fabrication and testing of steel componentry is all completed in house, before being hot-dip galvanised ready for final assembly.

The module is then fully assembled and tested one of our state-of-the-art facilities, ready for sign off and mounting to the truck of your choice.

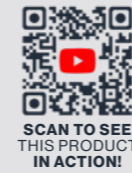

SCAN TO SEE
THIS PRODUCT
IN ACTION!



WE OFFER A RANGE OF SIZES



8,000 Litres



10,000 Litres



12,000 Litres



13,000 Litres



15,000 Litres



PLUG & PLAY WIRING

For Fast & Easy Wiring



BODY MOUNTING KIT

Engineer Approved
Brackets



INSTALLATION GUIDE SUPPLIED

Step by Step Guide



FACTORY TESTED BEFORE DISPATCH

Ready to Work!

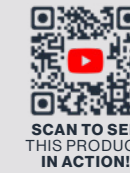

SCAN TO SEE
THIS PRODUCT
IN ACTION!

SLIP-ON WATER CARTS

FloodRite™

FloodRite™ slip on water carts are designed primarily for slipping into tipper trucks, or forklifting onto tray trucks.

Their perfect for general civil works or road construction, dust suppression or landscape watering.

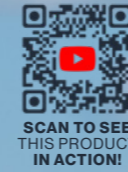

SCAN TO SEE THIS PRODUCT IN ACTION!

SLIP ON WATER CARTS

FEATURES



HANDHELD WIRELESS REMOTE CONTROL

Turn motor on/off, spray bar & dribble bar on/off. Easily switch trucks.



HEAVY-DUTY, FULLY BAFFLED POLY TANK

UV stabilized tank, suitable for potable water and backed by an industry best 20 year warranty.



1600L/MIN SELF PRIMING PUMP

1600L/min Self Priming Pump with Honda Petrol or Yanmar Diesel Engines.



HEAVY DUTY GALVANISED SKID FRAME

The tank is mounted on a heavy duty skid frame, which incorporates forklift pockets.



20M SPRING RETRACTABLE HOSE REEL

Heavy-duty spring rewind multi-purpose hose reel, fitted with 20m of 25mm wash down hose and adjustable nozzle.



ERGONOMIC PIPEWORK MANIFOLD

Fully welded and hot dip galvanised pipework manifold, with actuators & valves.



STANDPIPE, HYDRANT & SUCTION FILL CAPABILITIES

3" Hydrant Funnel fill lid, hydrant system with air-gap & 6m quick fill kit for suction filling.



3" REAR ADJUSTABLE SPRAY HEADS

Fully adjustable & individually operated rear spray heads.

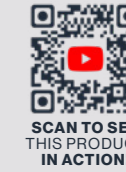

SCAN TO SEE THIS PRODUCT IN ACTION!

WE OFFER A RANGE OF SIZES

SLIP ON WATER CARTS

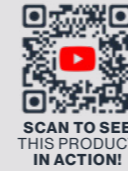

6,000 Litres

3600 x 2000 x 1990mm (LWH) / 1,200kg



8,000 Litres

4400 x 2100 x 1990mm (LWH) / 1,450kg



10,000 Litres

4400 x 2100 x 2330mm (LWH) / 1,550kg



12,000 Litres

4400 x 2100 x 2690mm (LWH) / 1,680kg



13,000 Litres

4200 x 2250 x 2760mm (LWH) / 1,680kg



13,000 Litres (Low-Profile)

5400 x 2370 x 2240mm (LWH) / 1,770kg



15,000 Litres

5400 x 2370 x 2490mm (LWH) / 1,860kg



17,000 Litres

5400 x 2370 x 2840mm (LWH) / 1,950kg

EASY LOADING & UNLOADING FROM TIPPERS

OPTIONAL SWING-UP LEG SYSTEM



OPTIONS

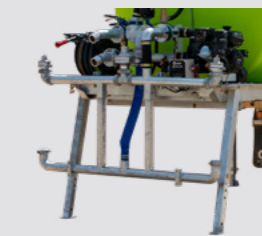

Self-Loading Legs



Dribble Bar



Water Cannon

HOOKLIFT WATER CARTS

Hooklift™

FloodRite Hooklift water carts are designed primarily for Hooklift trucks.

They're perfect for general civil works or road construction, dust suppression or landscape watering.

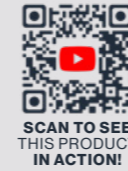

10,000 Litres



13,000 Litres



15,000 Litres

HOOKLIFT WATER CARTS

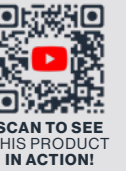

FEATURES



HANDHELD WIRELESS REMOTE CONTROL

Turn motor on/off, spray bar & dribble bar on/off. Easily switch trucks.



HEAVY-DUTY, FULLY BAFFLED POLY TANK

UV stabilized tank, suitable for potable water & backed by an industry best 20 year warranty

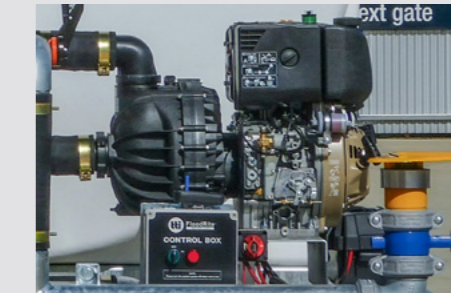

1600L/MIN SELF PRIMING PUMP

Self Priming Pump coupled with KOHLER Diesel electric start engines, with battery pack



HEAVY-DUTY GALVANISED SKID FRAME

The tank is mounted on a heavy duty skid frame, with an a-frame



20M SPRING RETRACTABLE HOSE REEL

Heavy-duty spring rewind multi-purpose hose reel, fitted with 20m of 25mm wash down hose and adjustable nozzle



ERGONOMIC PIPEWORK MANIFOLD

Fully welded and hot dip galvanised pipework manifold, with actuators & valves



STANDPIPE, HYDRANT & SUCTION FILL CAPABILITIES

3" Hydrant Funnel fill lid, hydrant system with air-gap & 6m quick fill kit for suction filling



3" REAR ADJUSTABLE SPRAY HEADS

Fully adjustable & individually operated rear spray heads

xTreme™

Pressure Cleaning Trailer



Heavy-Duty Cold Wash Pressure Cleaning Trailer

Heavy-duty pressure cleaning trailers are ideal for councils, civil and industrial use, with high performing pressure cleaning pumps ideal for removing heavy grime and dirt

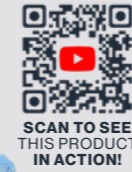

KEY FEATURES



Heavy-Duty Poly Tank
Australian Made, Tough,
Lightweight and Rust-Free
Polyethylene Cartage Tank
with 25-Year Warranty



Pressure Cleaning Kit
Choice of Honda petrol or
Kubota diesel engines with
Spitwater pressure cleaner
pumps (3650psi)

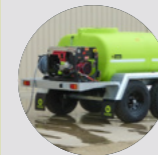

Heavy-Duty Chassis
A well balanced, easy towing,
fully hot dipped galvanised
chassis is engineer approved,
for years of hard work



20m Hose Reel
Convenient 20m hose reel
with heavy duty braid hose
& quality spray wand



LiquidLocker™ Baffles
Fitted for safety and stability,
LiquidLocker™ baffles are
included in every xTreme™ Trailer

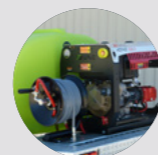

High Pressure Pump
High performing pumps rated
to 3150-3650psi pumps get
the job done with ease!

*GST included | Free Call 1800 816 277 | www.tti.com.au

xTreme™ PLUS

Pressure Cleaning & Washdown Trailer



Powerful Pressure Cleaning & Washdown Trailer

Dual purpose pressure cleaning & washdown trailers are ideal for councils, civil and industrial use. Separate pressure cleaning & washdown pumps enable you tackle any application

*GST included | Freight Rates Apply

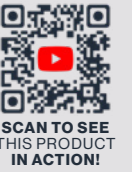
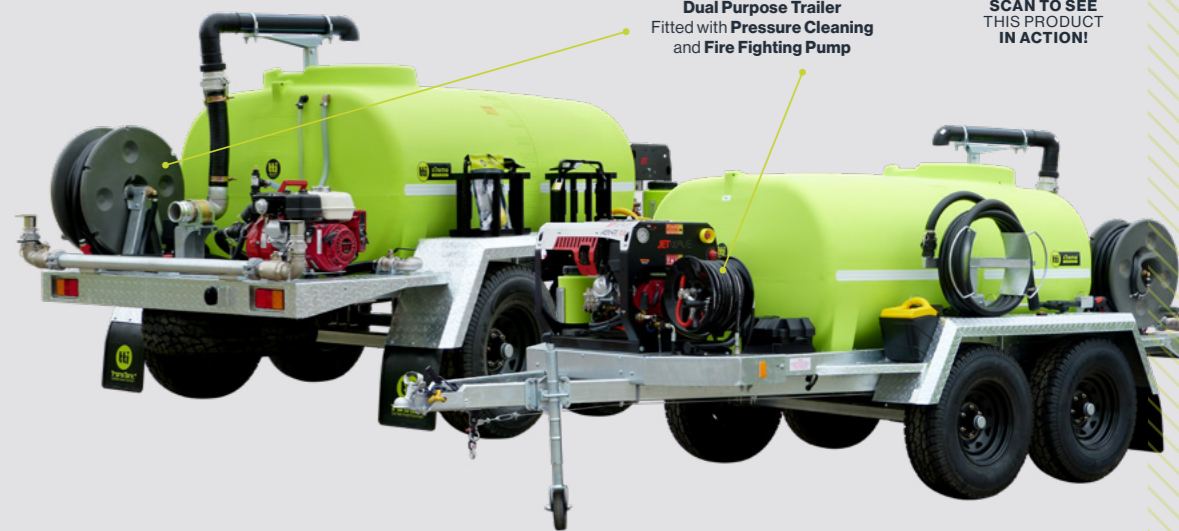

Dual Purpose Trailer
Fitted with Pressure Cleaning
and Fire Fighting Pump

KEY FEATURES



Heavy-Duty Poly Tank
Australian Made, Tough,
Lightweight and Rust-Free
Polyethylene Cartage Tank
with 25-Year Warranty



Washdown Pump Kit
Choice of Honda petrol or
Yanmar diesel engines with
Davey pump for washdown;
36m x 19mm hose and reel

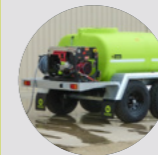

Heavy-Duty Chassis
A well balanced, easy towing,
fully hot dipped galvanised
chassis is engineer approved,
for years of hard work

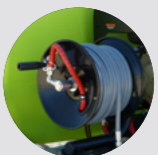

Pressure Cleaning Kit
Choice of Honda petrol or Kubota
diesel engines with Spitwater
pressure cleaner pumps (3650psi)

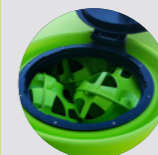

LiquidLocker™ Baffles
Fitted for safety and stability,
LiquidLocker™ baffles are
included in every xTreme™ Trailer

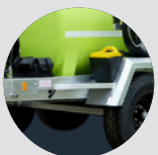

15" Sunraysia Landcruiser
wheels makes for smooth towing
even in the toughest terrain

Trans Tank® International | Product Catalogue 2025

153

OUR PEOPLE

OUR STAFF - OUR KEY!

At TTI we believe that anyone can copy the products we manufacture, the marketing we produce, the facilities we have, but nobody can copy the people that make the company what it is.

Our people and their families mean everything to us and always will.

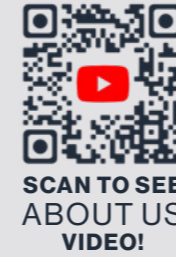

SCAN TO SEE ABOUT US VIDEO!

SOME OF US!



Andre Büchner
Director



Ross Büchner
Chief Executive Officer



Rolf Büchner
National Sales Manager



Jens Büchner
Marketing Manager



Richard Southall
Operations Manager



Wayde Büchner
Head of Innovation



Andrew Trappel
National Key Account Manager- AG



Kevin Büchner
Industrial Product Specialist



Dale James
Product Specialist



Sidney Ferguson
Digital Marketing Manager



Pierre Büchner
TTi Ambassador



Elmer Selby
SA/NT State Manager



Laura Steward
Receptionist/Admin Assistant



Joseph Patten
Technical Team Leader



Jedd Büchner
Product Specialist



Rick Hansen
Dealer Support Specialist



Andrea Boschetti
Sales Support



Paul Kiesskalt
Customer Service Team Leader



Brian Boyd
Customer Care Coordinator

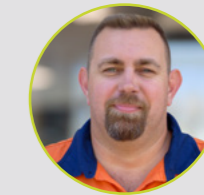

Craig Hook
Warehouse, Dispatch & Conveyancing Supervisor

www.tti.com.au

FREIGHT RATE GUIDE

Call to Discuss Your Tailored Freight Pricing
1800 816 277

Having trouble locating your dealer?
Call **1800 816 277** or visit www.tti.com.au

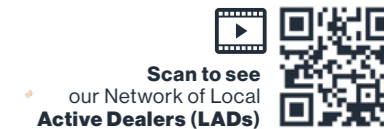

ZONES



All Bare Tanks	100L to 400L	\$70	\$100	\$125	\$140	\$210	POA
	500L to 1,500L	\$125	\$200	\$240	\$360	\$425	POA
	2,000L to 4,000L	\$240	\$440	\$495	\$550	\$770	POA
	5,000L to 12,000L	\$550	\$690	\$1,000	POA	POA	POA
	13,000L to 17,000L	\$690	\$1,000	POA	POA	POA	POA

Inter™ / WeedMasta™	All Sizes	\$35	\$35	\$35	\$35	\$45	POA
---------------------	-----------	------	------	------	------	------	-----

WeedControl™	55L to 95L	\$45	\$55	\$65	\$90	\$100	POA
	150L to 225L	\$65	\$90	\$110	\$130	\$165	POA

OnDeck™/ReelStrike™	200L to 400L	\$110	\$165	\$250	\$275	\$410	POA
---------------------	--------------	-------	-------	-------	-------	-------	-----

TopCrop™	500L to 1,000L	\$275	\$410	\$550	\$660	POA	POA
----------	----------------	-------	-------	-------	-------	-----	-----

WeedControl™ Trailers	55L / 95L / 150L	\$85	\$100	\$110	\$155	\$175	POA
-----------------------	------------------	------	-------	-------	-------	-------	-----

TrailPro™	200L	\$140	\$210	\$275	\$415	\$440	POA
	400L	\$275	\$485	\$605	POA	POA	POA

GlidePath™	800L to 1,200L	\$550	\$1,000	POA	POA	POA	POA
------------	----------------	-------	---------	-----	-----	-----	-----

LinkOn™	300L to 400L	\$140	\$275	\$385	POA	\$550	POA
	600L to 1,000L	\$210	\$415	POA	POA	POA	POA

Booms or Versatile Boom	2m - 4m	\$60	\$80	\$100	\$150	\$150	POA
-------------------------	---------	------	------	-------	-------	-------	-----

Booms	6m - 8m	\$110	\$140	\$210	\$250	\$275	POA
	10m - 12m	\$210	\$275	\$485	POA	POA	POA

Hose Reels	30m - 50m	\$45	\$55	\$65	\$65	\$75	POA
	Fire Hose / SuperReels	\$65	\$90	\$110	\$130	\$130	POA

ZONES



Diesel Units	100L to 400L	\$70	\$85	\$110	\$110	\$165	POA
	440L to 600L	\$120	\$140	\$275	\$300	\$350	POA
	800L to 1,200L	\$175	\$240	\$300	\$350	\$440	POA
	1,500L to 4,000L	\$300	\$600	\$825	POA	POA	POA
	5,000L to 10,000L	\$550	\$900	\$1,200	POA	POA	POA

Diesel Trailers	Single Axle	\$550	\$1,000	POA	POA	POA	POA
	Dual Axle	\$750	\$1,200	POA	POA	POA	POA

Fire Units	220L to 300L	\$100	\$130	\$165	\$275	\$275	POA
	400L to 1,500L	\$140	\$200	\$275	\$480	POA	POA

Fire Units / AquaPath™	2,000L to 4,000L	\$400	\$685	\$960	POA	POA	POA
	5,000L to 6,000L	\$550	\$825	\$1,200	POA	POA	POA

Fire Trailers	800L to 1,200L	\$550	\$1,000	POA	POA	POA	POA
	1,500L to 3,000L	\$750	\$1,100	POA	POA	POA	POA

AquaDelivery™ / FloodRite™ Water Trucks		POA	POA	POA	POA	POA	POA
---	--	-----	-----	-----	-----	-----	-----

NOTE:

If multiple products are being ordered, Please contact for consolidated freight quote.

Call 1800 816 277 for details.

LEGEND:

- Zone 1
- Zone 2
- Zone 3
- Zone 4
- Zone 5
- Zone 6

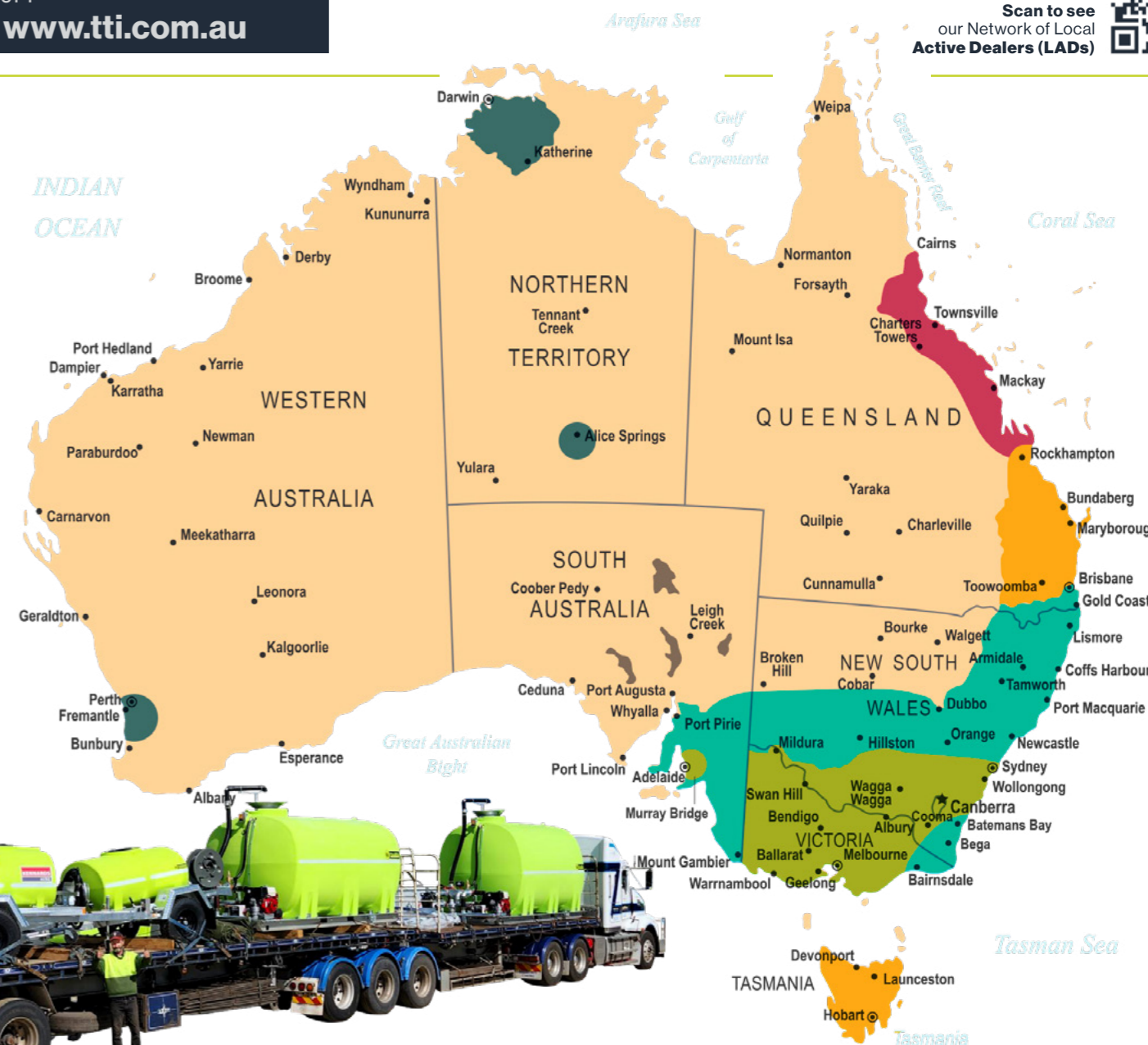



TransTank[®]
INTERNATIONAL

HEAD OFFICE [NATHALIA]

3 Murray Valley Hwy,
Nathalia, VIC, 3638

FABRICATION [NATHALIA]

5 Nugent St,
Nathalia, VIC, 3638

WATER TRUCKS [MELBOURNE]

12 Burwood Avenue,
Sunshine North, VIC, 3020



QUOTES AND ENQUIRIES

1800 816 277

HEAD OFFICE

Head Office: **1800 816 277**
Landline: (03) **5866 3266**
Fax: (03) **5866 3019**

EMAIL

Sales: **sales@tti.com.au**
Marketing: **marketing@tti.com.au**
Operations: **operations@tti.com.au**
Accounts Receivable: **accountsreceivable@tti.com.au**
Accounts Payable: **accountspayable@tti.com.au**
Support/Warranty: **support@tti.com.au**

ONLINE

www.**tti.com.au**
www.**ttiwatertrucks.com.au**



Follow us at **#TransTankInternational**